

This manual contains important warnings and information.  
**READ AND RETAIN FOR REFERENCE**

**INSTRUCTIONS**

120 VAC, 18 AMP

## Ultra 1500 Airless Paint Sprayer

3000 psi (210 bar) Maximum Working Pressure

### Part No. 220-627, Series B

Basic Sprayer on upright cart without hose or gun.

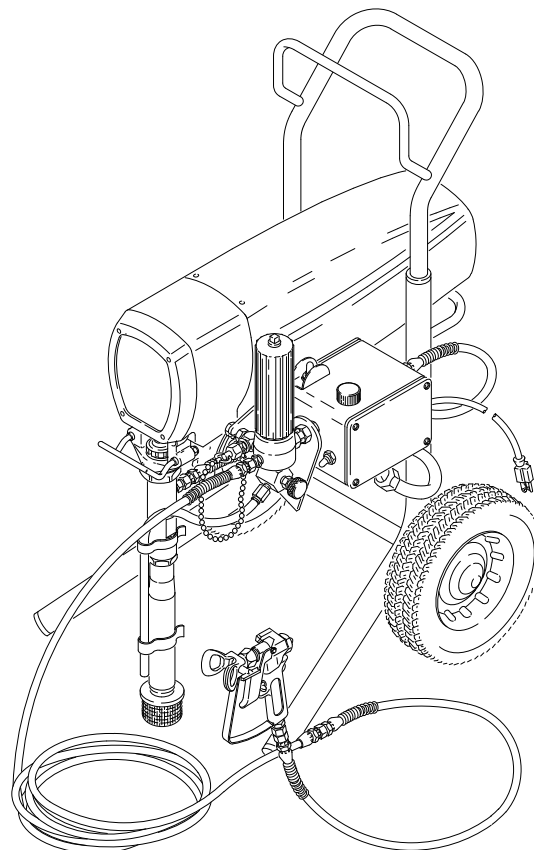
### Part No. 231-053

Complete sprayer on upright cart with hose, gun, RAC IV® DripLess™ Tip Guard and SwitchTip™

### Part No. 223-773, Series A

Same as Model 220-627, except CSA certified

Patents Pending



01888

### Table of Contents

Warnings .....	2
Setup .....	8
Operation .....	9
Flushing .....	11
Troubleshooting .....	12
Motor Brush Replacement .....	14
Displacement Pump Repair .....	15
General Repair .....	20
Parts, Sprayer .....	24
Parts, Displacement Pump .....	26
Danger Labels .....	27
Technical Data .....	28
Dimensions .....	28
Graco Phone Numbers .....	28
The Graco Warranty and Disclaimers .....	28

**NOTE:** This is an example of the English language DANGER label on your sprayer. This label is supplied with the sprayer in other languages. Before operating the sprayer, apply a DANGER label in the appropriate language for your operators, according to the separate instructions supplied with it.

<span style="float: left;">⚠</span> <span style="font-size: 2em; font-weight: bold; letter-spacing: 0.5em;">DANGER</span> <span style="float: right;">⚠</span>			
	<b>FIRE AND EXPLOSION HAZARD</b>		<b>SKIN INJECTION HAZARD</b>
<p>Spray painting, flushing or cleaning equipment with flammable liquids in confined areas can result in fire or explosion.</p> <p>Use outdoors or in extremely well ventilated areas. Ground equipment, hoses, containers and objects being sprayed.</p> <p>Avoid all ignition sources such as static electricity from plastic drop cloths, open flames such as pilot lights, hot objects such as cigarettes, arcs from connecting or disconnecting power cords or turning light switches on and off.</p> <p>Failure to follow this warning can result in death or serious injury.</p>	<p>Liquids can be injected into the body by high pressure airless spray or leaks – especially hose leaks.</p> <p>Keep body clear of the nozzle. Never stop leaks with any part of the body. Drain all pressure before removing parts. Avoid accidental triggering of gun by always setting safety latch when not spraying.</p> <p>Never spray without a tip guard.</p> <p>In case of accidental skin injection, seek immediate “Surgical Treatment”.</p> <p>Failure to follow this warning can result in amputation or serious injury.</p>	<p style="text-align: center; font-weight: bold;">READ AND UNDERSTAND ALL LABELS AND INSTRUCTION MANUALS BEFORE USE</p>	

# WARNINGS

**High Pressure Spray Can Cause Serious Injury. For Professional Use Only.**  
**Observe All Warnings. Read and understand all instruction manuals before operating equipment.**

## FLUID INJECTION HAZARD

### General Safety

This equipment generates very high fluid pressure. Spray from the gun, leaks or ruptured components can inject fluid through your skin and into your body and cause extremely serious injury, including the need for amputation. Also, fluid injected or splashed into the eyes or on the skin can cause serious damage.

NEVER point the spray gun at anyone or at any part of the body. NEVER put hand or fingers over the spray tip. NEVER try to “blow back” paint; this is NOT an air spray system.

ALWAYS have the tip guard in place on the spray gun when spraying.

ALWAYS follow the **Pressure Relief Procedure**, below, before cleaning or removing the spray tip or servicing any system equipment.

NEVER try to stop or deflect leaks with your hand or body.

Be sure equipment safety devices are operating properly before each use.

### Medical Alert—Airless Spray Wounds

If any fluid appears to penetrate your skin, get **EMERGENCY MEDICAL CARE AT ONCE. DO NOT TREAT AS A SIMPLE CUT.** Tell the doctor exactly what fluid was injected.

**Note to Physician:** Injection in the skin is a traumatic injury. It is important to treat the injury surgically as soon as possible. **Do not delay treatment to research toxicity.** Toxicity is a concern with some exotic coatings injected directly into the blood stream. Consultation with a plastic surgeon or reconstructive hand surgeon may be advisable.

### Spray Gun Safety Devices

Be sure all gun safety devices are operating properly before each use. Do not remove or modify any part of the gun; this can cause a malfunction and result in serious injury.

### Safety Latch

Whenever you stop spraying, even for a moment, always set the gun safety latch in the closed or “safe” position, making the gun inoperative. Failure to set the safety latch can result in accidental triggering of the gun.

### Diffuser

The gun diffuser breaks up spray and reduces the risk of fluid injection when the tip is not installed. Check diffuser operation regularly. Follow the **Pressure Relief Procedure**, below, then remove the spray tip. Aim the gun into a metal pail, holding the gun firmly to the pail. Using the lowest possible pressure, trigger the gun. If the fluid emitted is *not* diffused into an irregular stream, replace the diffuser immediately.

### Tip Guard

ALWAYS have the tip guard in place on the spray gun while spraying. The tip guard alerts you to the fluid injection hazard and helps reduce, but does not prevent, the risk of accidentally placing your fingers or any part of your body close to the spray tip.

### Trigger Guard

Always have the trigger guard in place on the gun when spraying to reduce the risk of accidentally triggering the gun if it is dropped or bumped.

### Spray Tip Safety

Use extreme caution when cleaning or changing spray tips. If the spray tip clogs while spraying, engage the gun safety latch immediately. ALWAYS follow the **Pressure Relief Procedure** and then remove the spray tip to clean it.

NEVER wipe off build-up around the spray tip until pressure is fully relieved and the gun safety latch is engaged.

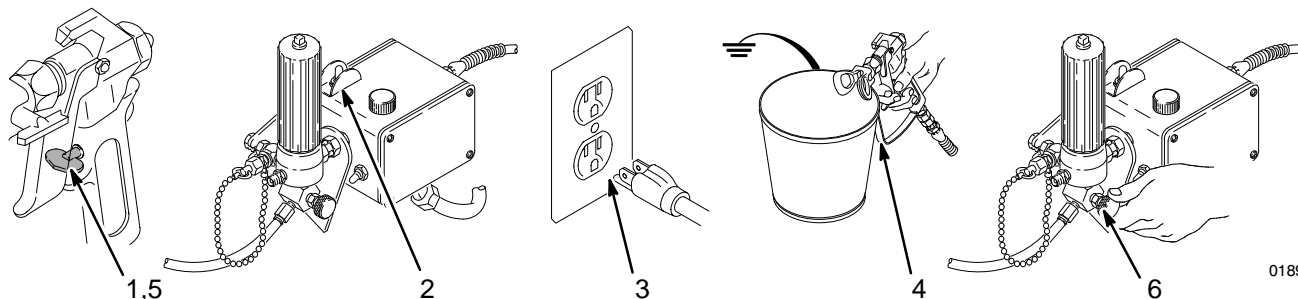
### Pressure Relief Procedure

To reduce the risk of serious injury, including fluid injection, splashing fluid or solvent in the eyes or on the skin, or injury from moving parts or electric shock, always follow this procedure whenever you shut off the sprayer, when checking or servicing any part of the spray system, when installing, cleaning or changing spray tips, and whenever you stop spraying.

1. Engage the gun safety latch.
2. Turn the ON/OFF switch to OFF.
3. Unplug the power supply cord.

4. Disengage the gun safety latch. Hold a metal part of the gun firmly to the side of a grounded metal pail, and trigger the gun to relieve pressure.
5. Engage the gun safety latch.
6. Open the pressure drain valve, having a container ready to catch the drainage. Leave the valve open until you are ready to spray again.

*If you suspect that the spray tip or hose is completely clogged, or that pressure has not been fully relieved after following the steps above, wrap a rag around the tip guard retaining nut or hose end coupling and VERY SLOWLY loosen the part to relieve pressure gradually, then loosen completely. Now clear the tip or hose.*



01890

---

## MOVING PARTS HAZARD

---

Moving parts can pinch or amputate your fingers or other body parts. KEEP CLEAR of moving parts when starting or operating the sprayer. Follow the **Pressure Relief Procedure** on page 2

before checking or servicing any part of the sprayer, to prevent it from starting accidentally.

---

## EQUIPMENT MISUSE HAZARD

---

### General Safety

Any misuse of the spray equipment or accessories, such as overpressurizing, modifying parts, using incompatible chemicals and fluids, or using worn or damaged parts, can cause them to rupture and result in fluid injection, splashing in the eyes or on the skin, or other serious injury, or fire, explosion or property damage.

NEVER alter or modify any part of this equipment; doing so could cause it to malfunction.

CHECK all spray equipment regularly and repair or replace worn or damaged parts immediately.

Always wear protective eyewear, gloves, clothing and respirator as recommended by the fluid and solvent manufacturer.

### System Pressure

This sprayer can develop *3000 psi (210 bar) MAXIMUM*

**WORKING PRESSURE.** Be sure that all spray equipment and accessories used are rated to withstand this pressure. DO NOT exceed the maximum working pressure of any component or accessory used in the system.

### Fluid and Solvent Compatibility

All chemicals used in the sprayer must be chemically compatible with the wetted parts shown in the **TECHNICAL DATA** on page 26. Consult your chemical supplier to ensure compatibility.

Do not use 1,1,1-trichloroethane, methylene chloride, other halogenated hydrocarbon solvents or fluids containing such solvents in this equipment, which contains aluminum and/or zinc parts. Such use could result in a serious chemical reaction, with the possibility of explosion, which could cause death, serious injury and/or substantial property damage.

---

## HOSE SAFETY

---

High pressure fluid in the hoses can be very dangerous. If the hose develops a leak, split or rupture due to any kind of wear, damage or misuse, the high pressure spray emitted from it can cause a fluid injection injury or other serious injury or property damage.

**All fluid hoses must have spring guards on both ends!** The spring guards help protect the hose from kinks or bends at or close to the coupling which can result in hose rupture.

TIGHTEN all fluid connections securely before each use. High pressure fluid can dislodge a loose coupling or allow high pressure spray to be emitted from the coupling.

NEVER use a damaged hose. Before each use, check the entire hose for cuts, leaks, abrasion, bulging cover, or damage or movement of the hose couplings. If any of these conditions exist, replace the hose immediately. DO NOT try to recouple high pressure hose or mend it with tape or any other device. A repaired hose cannot contain the high pressure fluid.

Handle and route hoses carefully. Do not pull on hoses to move equipment. Keep hoses clear of moving parts and hot surfaces of the pump and gas engine. Do not use fluids or solvents which are not compatible with the inner tube and cover of the hose. DO NOT expose Graco hose to temperatures above 180° F (82° C) or below -40° F (-40° C).

### Hose Grounding Continuity

Proper hose grounding continuity is essential to maintaining a grounded spray system. Check the electrical resistance of your fluid hoses at least once a week. If your hose does not have a tag on it which specifies the maximum electrical resistance, contact the hose supplier or manufacturer for the maximum resistance limits. Use a resistance meter in the appropriate range for your hose to check the resistance. If the resistance exceeds the recommended limits, replace it immediately. An ungrounded or poorly grounded hose can make your system hazardous. Also read **FIRE OR EXPLOSION HAZARD**.

---

## FIRE OR EXPLOSION HAZARD

---

Static electricity is created by the flow of fluid through the pump and hose. If every part of the spray equipment is not properly grounded, sparking may occur, and the system may become hazardous. Sparking may also occur when plugging in or unplugging a power supply cord or using a gasoline engine. Sparks can ignite fumes from solvents and the fluid being sprayed, dust particles and other flammable substances, whether you are spraying indoors or outdoors, and can cause a fire or explosion and serious injury and property damage.

If you experience any static sparking or even a slight shock while using this equipment, **Stop spraying immediately.** Check the entire system for proper grounding. Do not use the system again until the problem has been identified and corrected.

### Grounding

To reduce the risk of static sparking, ground the sprayer and all other spray equipment used or located in the spray area. CHECK your local electrical code for detailed grounding instructions for your area and type of equipment. BE SURE to ground all of this spray equipment:

1. *Sprayer:* plug into a properly grounded outlet. Do not remove the grounding prong of the plug, and do not use an adapter. Extension cords must have three wires.

2. *Fluid hoses:* use only grounded hoses with a maximum of 500 ft (150 m) combined hose length to ensure grounding continuity. See **Hose Grounding Continuity**.
3. *Spray gun:* obtain grounding through connection to a properly grounded fluid hose and sprayer.
4. *Object being sprayed:* according to local code.
5. *Fluid supply container:* according to local code.
6. *All solvent pails used when flushing,* according to local code. Use only metal pails, which are conductive. Do not place the pail on a non-conductive surface, such as paper or cardboard, which interrupts the grounding continuity.
7. *To maintain grounding continuity when flushing or relieving pressure,* always hold a metal part of the gun firmly to the side of a grounded metal pail, then trigger the gun.

### Flushing Safety

Reduce the risk of fluid injection injury, static sparking, or splashing by following the flushing procedure given on page 11 of this manual. Follow the **Pressure Relief Procedure** on page 2, and remove the spray tip before flushing. Hold a metal part of the gun firmly to the side of a grounded metal pail and use the lowest possible fluid pressure during flushing.

---

## IMPORTANT

---

United States Government safety standards have been adopted under the Occupational Safety and Health Act. These standards – particularly the General Standards, Part 1910, and the Construction Standards, Part 1926 – should be consulted.

# Avertissement

La pulvérisation à haute pression peut causer des blessures très graves.  
Réservé exclusivement à l'usage professionnel. Observer toutes les consignes de sécurité.  
Bien lire et bien comprendre tous les manuels d'instructions avant d'utiliser le matériel.

## RISQUES D'INJECTION

### Consignes générales de sécurité

Cet appareil produit un fluide à très haute pression. Le fluide pulvérisé par le pistolet ou le fluide sous pression provenant de fuites ou de ruptures peut pénétrer sous la peau ou à l'intérieur du corps et entraîner des blessures très graves, voir même une amputation. Même sans être sous pression, le fluide éclaboussant ou entrant dans les yeux peut aussi entraîner des blessures graves.

NE JAMAIS pointer le pistolet vers quelqu'un ou vers une partie quelconque du corps. NE JAMAIS mettre la main ou les doigts sur l'ajutage du pulvérisateur. NE JAMAIS essayer de "refouler" la peinture. Cet appareil N'est PAS un compresseur pneumatique.

TOUJOURS garder la protection de l'ajutage en place sur le pistolet pendant la pulvérisation.

TOUJOURS observer la **Marche à Suivre pour Détendre la Pression** donnée plus loin, avant de nettoyer ou d'enlever l'ajutage du pulvérisateur, ou d'effectuer un travail quelconque sur une partie de l'appareil.

NE JAMAIS essayer d'arrêter ou de dévier les fuites avec la main ou le corps.

Avant chaque utilisation, bien s'assurer que les dispositifs de sécurité fonctionnent correctement.

### Soins médicaux

En cas de pénétration de fluide sous la peau: **DEMANDER IMMEDIATEMENT DES SOINS MEDICAUX D'URGENCE**. Ne pas soigner cette blessure comme une simple coupure.

*Avis au medecin:* La pénétration des fluides sous la peau est un traumatisme. **Il est important de traiter chirurgicalement cette blessure immédiatement**. Ne pas retarder le traitement pour effectuer des recherches sur la toxicité. Certains revêtements exotiques sont dangereusement toxiques quand ils sont injectés directement dans le sang. Il est souhaitable de consulter un chirurgien esthétique ou un chirurgien spécialisé dans la reconstruction des mains.

### Dispositifs de sécurité du pistolet

Avant chaque utilisation, bien s'assurer que tous les dispositifs de sécurité du pistolet fonctionnent correctement. Ne pas enlever ni

modifier une partie quelconque du pistolet; ceci risquerait d'entraîner un mauvais fonctionnement et des blessures graves.

### Verrou de sécurité

A chaque fois que l'on s'arrête de pulvériser, même s'il s'agit d'un court instant, toujours mettre le verrou de sécurité du pistolet sur la position "fermée" ou "sécurité" ("safe") pour empêcher le pistolet de fonctionner. Si le verrou de sécurité n'est pas mis, le pistolet peut se déclencher accidentellement. Voir la Fig. 1, ci-dessus.

### Diffuser

Le diffuseur du pistolet sert à diviser le jet et à réduire les risques d'injection accidentelle quand l'ajutage n'est pas en place. Vérifier le fonctionnement du diffuseur régulièrement. Pour cette vérification, détendre la pression en observant la **Marche à Suivre pour Détendre la Pression** donnée plus loin puis enlever l'ajutage du pulvérisateur. Pointer le pistolet dans un seau en métal, en le maintenant fermement contre le seau. Puis, en utilisant la pression la plus faible possible, appuyer sur la gachette du pistolet. Si le fluide projete *n'est pas* diffusé sous forme de jet irrégulier, remplacer immédiatement le diffuseur.

### Protection de l'ajutage

TOUJOURS maintenir la protection de l'ajutage en place sur le pistolet du pulvérisateur pendant la pulvérisation. La protection de l'ajutage attire l'attention sur les risques d'injection et contribue à réduire, mais n'évite pas le risque, que les doigts ou une partie quelconque du corps ne passent accidentellement à proximité immédiate de l'ajutage du pulvérisateur.

### Consignes de sécurité concernant l'ajutage du pulvérisateur

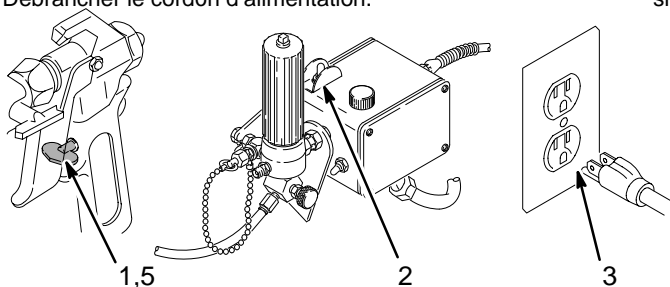
Faire extrêmement attention à l'occasion du nettoyage ou du remplacement des ajutages du pulvérisateur. Si l'ajutage se bouche pendant la pulvérisation, mettre immédiatement le verrou de sécurité du pistolet. TOUJOURS bien observer la **Marche à Suivre pour Détendre la Pression** puis enlever l'ajutage du pulvérisateur pour le nettoyer.

NE JAMAIS essayer ce qui s'est accumulé autour de l'ajutage du pulvérisateur avant que la pression ne soit complètement tombée et que le verrou de sécurité du pistolet ne soit engagé.

### Marche à Suivre pour Détendre la Pression

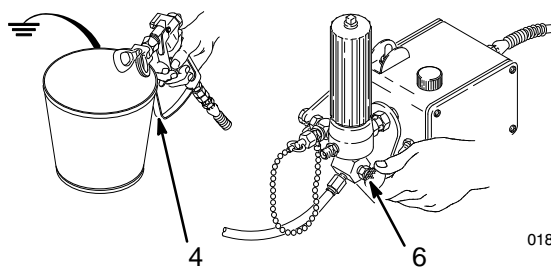
Pour réduire les risques de blessures graves, y compris les blessures par injection de fluide ou celles causées par des éclaboussures dans les yeux ou sur la peau, des pièces en mouvement ou par électrocution, toujours bien observer cette marche à suivre à chaque fois que l'on arrête le pulvérisateur, à l'occasion de la vérification, du réglage ou du nettoyage du système ou lors du changement des ajutages.

1. Engager le verrou de sécurité du pistolet.
2. Basculer l'interrupteur de commande de pression sur ARRÊT (OFF).
3. Débrancher le cordon d'alimentation.



4. Désengager le verrou de sécurité du pistolet. Tout en maintenant une partie métallique du pistolet fermement appuyée contre le côté d'un seau en métal, actionner le pistolet pour libérer la pression.
5. Engager le verrou de sécurité du pistolet.
6. Ouvrir la soupape de sécurité et la laisser ouverte jusqu'à ce que l'on soit prêt à se servir de nouveau du pulvérisateur. Débrancher le fil de la bougie.

*Si l'on soupçonne que le tuyau ou l'ajutage du est complètement bouché, ou que la pression n'a pas été complètement libérée après avoir procédé aux opérations ci-dessus, desserrer très LENTEMENT un raccord du bout du tuyau ou l'écrou de retenue de la protection de l'ajutage et libérer progressivement la pression.*



01890

## RISQUES EN CAS DE MAUVAISE UTILISATION DU MATERIEL

### Consignes générales de sécurité

Toute utilisation anormale de l'appareil de pulvérisation ou des accessoires comme, par exemple, la mise sous une pression excessive, les modifications de pièces, l'utilisation de produits chimiques et de matières incompatibles et l'utilisation de pièces usées ou abîmées peut causer des dégâts à l'appareil ou des ruptures de pièces et entraîner une injection de liquide ou d'autres blessures sérieuses, un incendie, une explosion ou d'autres dégâts.

NE JAMAIS alterer ou modifier une pièce de cet appareil; ceci risquerait d'entraîner son mauvais fonctionnement.

Vérifier régulièrement tout l'appareil de pulvérisation et ses équipements et réparer ou remplacer immédiatement les pièces usées ou abîmées.

## MESURES DE SECURITE CONCERNANT LES TUYAUX FLEXIBLES

Le fluide à haute pression circulant dans les tuyaux peut être très dangereux. En cas de fuite sur le tuyau, de fissure, déchirure ou rupture à la suite de l'usure, de dégâts ou d'une mauvaise utilisation, les projections de fluide haute pression qui en proviennent peuvent entraîner des blessures graves par pénétration sous la peau ou par contact, ainsi que des dégâts matériels.

**Tous les tuyaux flexibles doivent avoir des ressorts spirale de protection aux bouts!** Les spirales de protection contribuent à éviter la formation de pliures, de boucles ou de nœuds sur les tuyaux qui pourraient entraîner la rupture du tuyau à l'endroit du raccord ou à son voisinage.

Serrer fermement tous les raccords avant chaque utilisation. Le fluide sous pression peut faire sauter un raccord desserré ou produire un jet à haute pression s'échappant par le raccord.

NE JAMAIS utiliser un tuyau endommagé. NE PAS essayer de refaire le raccord d'un tuyau haute pression ni de réparer le tuyau avec du ruban adhésif ou par tout autre moyen. Un tuyau réparé ne peut pas résister au fluide sous pression.

## RISQUES D'INCENDIE OU D'EXPLOSION

De l'électricité statique est produite par le passage du fluide à grande vitesse dans la pompe et dans les tuyaux. Si toutes les pièces de l'appareil de pulvérisation ne sont pas convenablement reliées à la masse ou à la terre, des étincelles peuvent se produire et l'appareil risque d'être dangereux. Des étincelles peuvent également se produire à l'occasion du branchement ou du débranchement du cordon d'alimentation. Les étincelles sont suffisantes pour allumer les vapeurs de solvants et le fluide pulvérisé, les fines particules de poussière ainsi que d'autres substances inflammables, quand on pulvérise à l'intérieur ou à l'extérieur, et elles peuvent causer un incendie ou une explosion, ainsi que des blessures graves et des dégâts matériels. Toujours brancher le pulvérisateur dans une prise se trouvant à au moins 6 m (20 pieds) de l'appareil et de l'endroit où se fait la pulvérisation. Ne pas brancher ou débrancher un cordon d'alimentation quel qu'il soit dans la zone où se fait la pulvérisation quand il y a le moindre risque que des vapeurs encore présentes dans l'air prennent feu.

S'il se produit des étincelles d'électricité statique, ou si vous ressentez la moindre décharge, ARRÊTEZ IMMÉDIATEMENT LA PULVÉRISATION. Vérifiez que le système entier est bien mis à terre. Ne vous servez pas du système avant que le problème soit identifié et corrigé.

### Mise à la terre ou à la masse

Pour réduire les risques de production d'étincelles d'électricité statique, le pulvérisateur et tous les équipements utilisés ou se trouvant dans la zone de pulvérisation doivent être reliés à la terre ou à la masse. Pour connaître le détail des instructions de mise à la terre dans la région et le type particulier d'équipement, CONSULTER le code ou les réglementations électriques locales. S'ASSURER que tous les équipements de pulvérisation suivants sont bien reliés à la terre:

1. *Pulvérisateur:* Brancher le cordon d'alimentation ou la rallonge qui doivent être équipés d'une prise à 3 fiches en bon état, dans une prise de courant convenablement mise à la terre. Ne pas utiliser d'adaptateur. Toutes les rallonges doivent avoir 3 fils.

### Pression

Ce pulvérisateur peut produire une **PRESSION MAXIMUM DE TRAVAIL** 210 bar (3000 lb/po2). S'assurer que tous les éléments du pulvérisateur et ses accessoires sont conçus pour résister à la pression maximum de travail de ce pulvérisateur. NE PAS dépasser la pression maximum de travail d'aucun des éléments ou accessoires utilisés avec cet appareil.

### Compatibilité chimique des corps

BIEN S'ASSURER que tous les corps des solvants utilisés sont chimiquement compatibles avec les parties mouillées indiquées dans les **Technical Data**, à page 26. Toujours lire soigneusement les documents et brochures du fabricant des fluides et solvants utilisés avant de s'en servir dans ce pulvérisateur.

Manipuler les tuyaux avec précaution et choisir soigneusement leur chemin. Ne pas déplacer le fluide en tirant sur le tuyau. Ne pas utiliser de fluides ou de solvants qui ne sont pas compatibles avec l'enveloppe intérieure ou extérieure du tuyau. NE PAS exposer le tuyau à des températures supérieures à 82° C (180° F) ou inférieures à -40° C (-40° F).

### Continuité de la mise à la terre des tuyaux

Une bonne continuité de la mise à la terre des tuyaux est essentielle pour maintenir la mise à la terre de l'ensemble de vaporisation. Vérifiez la résistance électrique de vos tuyaux à fluides et à air, au moins une fois par semaine. Si votre tuyau ne comporte pas d'étiquette qui précise la résistance électrique maximum, prenez contact avec le fournisseur de tuyaux ou le fabricant pour avoir les limites de résistance maximum. Utilisez un mètre de résistance de la gamme appropriée pour votre tuyau et vérifiez la résistance. Si celle-ci dépasse les limites recommandées, remplacez le tuyau immédiatement. Un tuyau sans mise à la terre ou avec une mise à la terre incorrecte peut entraîner des risques pour votre système. Lisez aussi **LES RISQUES D'INCENDIE OU D'EXPLOSION** ci-dessus.

2. *Tuyaux flexibles:* Afin d'assurer la continuité de la mise à la terre, n'utiliser que des tuyaux comportant une mise à la terre et ayant une longueur maximum combinée de 150 m (1500 pieds). Se reporter également au paragraphe **Continuité du circuit de mise à la terre des tuyaux**.
3. *Pistolet:* Réaliser la mise à la terre en le raccordant à un tuyau flexible et à un pulvérisateur déjà convenablement reliés à la terre.
4. *Réceptacle d'alimentation:* observer le code ou les réglementations locales.
5. *Objets, matériel ou surfaces recevant la pulvérisation:* observer le code ou les réglementations locales.
6. *Tous les seaux de solvants* utilisés pour le rinçage: observer le code ou les réglementations locales. N'utiliser que des seaux métalliques conducteurs de l'électricité. Ne pas mettre le seau sur une surface non conductrice comme sur du papier ou du carton car cela interromprait la continuité de la mise à la terre.
7. *Pour conserver la continuité de la mise à la terre quand on rince le matériel ou quand on libère la pression,* toujours maintenir une partie métallique du pistolet fermement appuyée contre le côté d'un seau en métal puis appuyer sur la détente du pistolet.

### Mesures de sécurité concernant le Rinçage

Pour réduire les risques de blessures par pénétration de la peau et les risques dus aux étincelles d'électricité statique ou aux éclaboussures, observer la marche à suivre pour le rinçage donnée à la page 11 de ce manuel. Observer la "Marche à Suivre pour Détendre la Pression" donnée à la page 4 en *enlever l'ajutage du pulvérisateur avant le rinçage*. Maintenir une partie métallique du pistolet fermement appuyée contre le côté d'un seau en métal et utiliser la pression la plus faible possible pendant le rinçage.

# ADVERTENCIA

El rociado a alta presión puede causar graves lesiones. Solo para uso profesional. respete los avisos de advertencia. Lea y entienda todo el manual de instrucciones antes de manejar el equipo.

## PELIGRO DE INYECCION DE FLUIDO

### Seguridad general

Este equipo genera un fluido a una presión muy alta. El rociado de la pistola, los escapes de fluido o roturas de los componentes pueden inyectar fluido en la piel y el cuerpo y causar lesiones extremadamente graves, incluyendo a veces la necesidad de amputación. También, el fluido inyectado o salpicado en los ojos puede causar graves daños.

NUNCA apuntar la pistola hacia alguien o alguna parte del cuerpo. NUNCA colocar la mano o los dedos encima de la boquilla. NUNCA tratar de "hacer retornar la pintura"; este NO es un sistema de rociado de aire.

SIEMPRE tener colocado el protector de la boquilla en la pistola mientras se está pulverizando.

SIEMPRE seguir el procedimiento de descarga de presión, dado más abajo, antes de limpiar o sacar la boquilla o de dar servicio a cualquier equipo del sistema.

NUNCA tratar de parar o desviar los escapes con la mano o el cuerpo.

Asegurar que todos los aparatos de seguridad del equipo están funcionando bien antes de cada uso.

### Tratamiento médico

Si pareciera que un poco de fluido penetró la piel, conseguir **TRATAMIENTO médico DE URGENCIA DE INMEDIATO. NO TRATAR LA HERIDA COMO UN SIMPLE CORTE.** Decir al médico exactamente cual fluido fue.

*Aviso al médico:* Si se llega a inyectar este fluido en la piel se causa una lesión traumática. **Es importante tratar quirúrgicamente la lesión a la brevedad posible.** No demorar el tratamiento para investigar la toxicidad. La toxicidad es algo de suma importancia en algunas pinturas exóticas cuando se inyectan directamente al torrente sanguíneo. Sirá conveniente consultar a un especialista en cirugía plástica o reconstructiva de las manos.

### Aparatos de seguridad de la pistola pulverizadora

Asegurar que todos los aparatos protectores de la pistola están funcionando bien antes de cada uso. No sacar ni modificar ninguna pieza de la pistola pues podría causar el malfuncionamiento de la misma con las consiguientes lesiones personales.

### Pestillo de seguridad

Cada vez que se deje de pulverizar, aunque sea por un breve momento, siempre colocar el pestillo de seguridad en la posición "cerrada" lo que deja la pistola inoperante. El no hacerlo puede llevar al disparo imprevisto de la pistola.

### Difusor

El difusor de la pistola dispersa el chorro pulverizado y reduce el riesgo de inyección cuando no está instalada la boquilla. Revisar con regularidad el funcionamiento del difusor. Seguir el **procedimiento de descarga de presión**, dado más abajo, y después sacar la boquilla. Apuntar la pistola a un balde metálico, sosteniéndola bien firme contra el. Utilizando la presión más bajo posible, disparar la pistola. Si el fluido emitido no sale disperso en un chorro irregular, reemplazar de inmediato el difusor.

### Protector de la boquilla

SIEMPRE tener el protector de la boquilla colocado en la pistola mientras se está pulverizando. Este protector llama la atención contra el peligro de inyección y ayuda a reducir, pero no evita, la colocación accidental de los dedos o cualquier otra parte del cuerpo cerca de la boquilla.

### Seguridad de la boquilla pulverizadora

Tener mucho cuidado al limpiar o cambiar las boquillas. Si llegara a obstruirse mientras está pulverizando, enganchar el pestillo de la pistola de inmediato. SIEMPRE seguir el **procedimiento de descarga de presión** y después sacar la boquilla para limpiarla.

NUNCA limpiar la acumulación de pintura alrededor de la boquilla antes de que se haya descargado por completo la presión y el pestillo este enganchado.

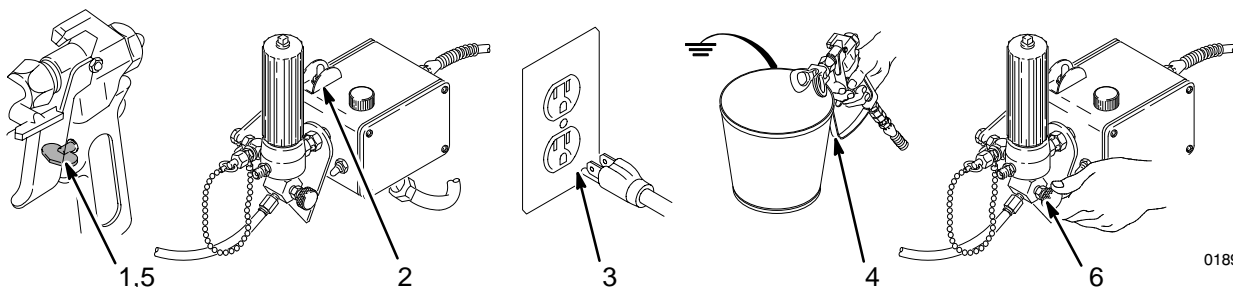
### Procedimiento de descarga de presión

Para reducir el riesgo de sufrir graves lesiones corporales, incluyendo inyección o lesiones causadas por piezán en movimiento o choque eléctrico, siempre seguir este procedimiento al apagar la máquina pulverizadora, al revisar o dar servicio a cualquier parte del sistema de pulverización, al instalar, limpiar o cambiar las boquillas, y cada vez que se deja de pulverizar.

1. Enganchar el pestillo de la pistola.
2. Mover el interruptor eléctrico (ON/OFF) a la posición OFF (apagado).
3. Desenchufar el cordón eléctrico.

4. Desenganchar el pestillo de la pistola. Sujetar una parte metálica de la pistola bien firme contra un balde de metal, y disparar la pistola para descargar la presión.
5. Enganchar el pestillo de la pistola.
6. Abrir la válvula de presión y tener listo un recipiente para recibir la pintura. Dejar la válvula de alivio de presión abierta hasta que se este nuevamente listo para pulverizar.

Si se sospecha que la boquilla o la manguera está completamente obstruida, o que no se ha descargado por completo la presión después de haber seguido el procedimiento anterior, aflojar **MUY LENTAMENTE** la tuerca de retención del protector de la boquilla o acoplamiento de la punta de la manguera y descargar gradualmente la presión, después, aflojarlo por completo. Luego, despejar la boquilla o la manguera.



01890

## PELIGRO POR MAL USO DEL EQUIPO

### Seguridad general

Cualquier mal uso del equipo pulverizador o los accesorios, tal como sobre presurización, modificación de piezas, uso de materiales y productos químicos incompatibles, o utilización de piezas dañadas o desgastadas, puede hacer que se rompan y causen la inyección de fluido u otras lesiones corporales graves, incendio, explosión o daño a la propiedad.

NUNCA alterar o modificar ninguna pieza de este equipo; el hacerlo podría causar una avería.

REVISAR con regularidad el equipo pulverizador y reparar o reemplazar de inmediato las piezas dañadas o desgastadas.

### Presión del sistema

está pulverizadora puede desarrollar 210 barías (3000 psi) de pres-

ión DE TRABAJO MÁXIMA. Asegurar que todo el equipo pulverizador y sus accesorios tienen la capacidad para aguantar la presión máxima de trabajo de esta pulverizadora. NO exceder la presión máxima de trabajo de ningún componente o accesorio de este sistema.

### Compatibilidad de fluido

Siempre leer las instrucciones del fabricante del fluido y solvente antes de usarlos en esta pulverizadora, dadas en la página 26.

Siempre usar gafas, guantes, vestimetas protectora y un respiradero, tal como recomiendan los fabricantes del fluido y del solvente.

## SEGURIDAD EN EL USO DE LAS MANGUERAS

El fluido que escapa a alta presión por las mangueras puede ser muy peligroso. Si en la manguera se desarrolla un escape, una rotura o rajadura debido a cualquier tipo de desgaste, daño o maltrato, el chorro a alta presión emitido por allí puede causar una lesión por inyección u otras lesiones corporales graves o daños a la propiedad.

**¡Todas las mangueras para fluidos tienen que tener guardas de resorte en ambos extremos!** Estas protegen las mangueras contra dobleces o retorceduras en los acoplamientos o cerca de ellos, los que podrían traducirse en roturas de la manguera.

Antes de usarlas, APRETAR bien firmes todas las conexiones. El fluido a alta presión puede desalojar un acoplamiento suelto o dejar que por el escape un chorro a alta presión.

NUNCA usar una manguera que está dañada. Siempre, revisarla en busca de cortaduras, escapes, abrasión, cubierta abultada, o acoplamientos sueltos o dañados. Si llegara a encontrarse cualquiera de estas condiciones, reemplazar de inmediato la manguera. NO intentar racoplar una manguera de alta presión o enmendarla con cinta adhesiva u otro material similar. Una manguera que ha sido remendada no aguante el fluido a alta presión.

Manejar y pasar cuidadosamente las mangueras. No tirar de las mangueras para mover el equipo. No usar fluidos o solventes que sean incompatibles con el tubo interno y la cubierta de la manguera. NO exponer las mangueras a temperaturas sobre 82<sup>o</sup> C (180<sup>o</sup> F) o bajo -40<sup>o</sup> C (-40<sup>o</sup> F).

### Continuidad del circuito de puesta a tierra de la manguera

La continuidad del circuito de puesta a tierra apropiado es esencial para mantener conectado a tierra el sistema pulverizador. Es indispensable revisar la resistencia eléctrica máxima de las mangueras de aire y de fluido por lo menos una vez a la semana. Si la manguera no tiene una etiqueta en la cual se especifica la resistencia eléctrica, ponerse en contacto con el proveedor o fabricante de la manguera para la información sobre los límites de resistencia. Usar un metro de resistencia en la gama apropiada para comprobar la resistencia; si excede los límites recomendados, reemplazarla de inmediato. Es muy arriesgado tener una manguera sin puesta a tierra o con la puesta a tierra en malas condiciones. Leer también la información sobre **RIESGO DE INCENDIO O EXPLOSION**, más arriba.

## PELIGRO DE INCENDIO O EXPLOSION

El flujo a alta velocidad del fluido al pasar por la bomba y manguera crea electricidad estática. Si todas las partes del equipo pulverizador no tienen buena tierra, pueden ocurrir chispas, convirtiendo al sistema en algo peligroso. También, pueden producirse chispas al enchufar o desenchufar el cordón eléctrico o al usar un motor de gasolina. Estas chispas pueden inflamar los vapores de los solventes y el chorro de fluido pulverizado, partículas de polvo y otras sustancias inflamables, sea al aire libre o bajo techo, lo que podría causar una explosión o incendio y graves lesiones corporales y daños a la propiedad. Enchufar siempre la pulverizadora a un tomacorriente que se encuentre a por lo menos 6 m (20 pies) de la máquina y del área que se va a rociar. No enchufar o desenchufar ningún cordón eléctrico en el lugar donde se está rociando cuando todavía exista la posibilidad de que queden vapores inflamables en el aire.

Si ocurre una chispa de electricidad estática o incluso un ligero choque eléctrico mientras se usa el equipo, DEJAR DE PULVERIZAR DE INMEDIATO. Revisar todo el sistema en busca de una tierra apropiada. No usar de nuevo el sistema hasta haber identificado y solucionado el problema.

### Puesta a tierra

Para reducir el riesgo de chispas estáticas, conectar a tierra la pulverizadora y todo el otro equipo de pulverizar que se use o se encuentre en el lugar que se va a rociar. CONSULTAR el código eléctrico de la localidad para las instrucciones sobre las conexiones a tierra exigidas para la zona y tipo de equipo. ASEGURAR de conectar a tierra todo este equipo pulverizador:

1. *Pulverizadora:* enchufar el cordón eléctrico, o cable extensor, cada uno un enchuf de tres patas en buen estado, a un tomacorriente con puesta a tierra apropiada. No usar un adaptador. Todos los cables extensores tienen que tener tres hilos.

2. *Mangueras para fluidos:* usar solamente mangueras con puesta a tierra de una longitud combinada de 150 m (500 pies), para asegurar buena continuidad a tierra. Referirse también al párrafo sobre **continuidad a tierra de la manguera**.
3. *Pistola:* hacer la puesta a tierra conectándola a una manguera de fluido y pulverizadora bien conectadas a tierra.
4. *Suministrar un recipiente:* de acuerdo al código de la localidad.
5. *Objeto que se está rociando:* de conformidad con el código local.
6. *Todos los baldes de solvente* usados durante el lavado, de conformidad con el código local. Usar *solamente baldes de metal*, que sean conductivos. no colocar el balde en una superficie no conductiva, como papel o cartón, que interrumpe la continuidad a tierra.
7. *Para mantener la continuidad a tierra durante el lavado o descarga de presión,* siempre apoyar una parte metálica de la pistola bien firme contra el costado del *balde de metal*, después apretar el gatillo.

### Seguridad durante el lavado

Para reducir el riesgo de que se inyecte o salpique fluido en la piel, o que ocurra una descarga de electricidad estática, siempre seguir las INSTRUCCIONES PARA EL LAVADO, dadas en la página 11. Seguir el **procedimiento de descarga de presión** en la página 6, y quitar la *boquilla rociadora antes de lavar*. Apoyar una parte metálica de la pistola bien firme contra el costado de un *balde de metal* y usar la presión más baja posible de fluido durante el lavado.

# Setup

## WARNING

Proper electrical grounding is essential to reduce the risk of fire or explosion which can result in serious bodily injury and property damage. See the warning section **FIRE OR EXPLOSION HAZARD** on page 3 for more detailed grounding instructions.

## WARNING

If you are supplying the hoses and spray gun, be sure the hoses are electrically conductive, that the gun has a tip guard, and that each part is rated for at least *3000 psi (210 bar) Working Pressure*. This is to reduce the risk of serious bodily injury caused by static sparking, fluid injection or over-pressurization and rupture of the hose or gun.

## CAUTION

To avoid damaging the pressure control, which may result in poor equipment performance and component damage, follow these precautions:

1. Use nylon spray hose at least 50 ft. long.
2. Never use a wire braid hose; it is too rigid to act as a pulsation dampener.
3. Never install any shutoff device between the filter and the main hose. See Fig. 1.

5. With the the **ON/OFF switch OFF**, plug the cord into a **grounded electrical outlet** located at least 20 ft. (6 m) away from the spray area.
6. **Flush the pump** to remove the lightweight oil which was left in to protect pump parts after factory testing. See page 11.

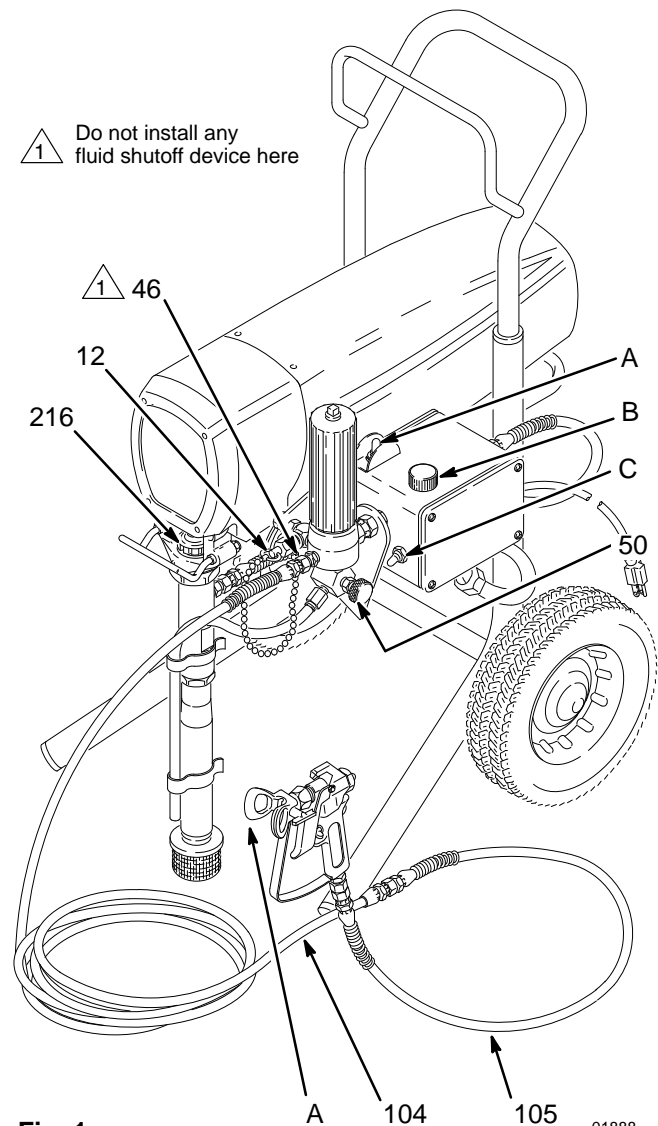
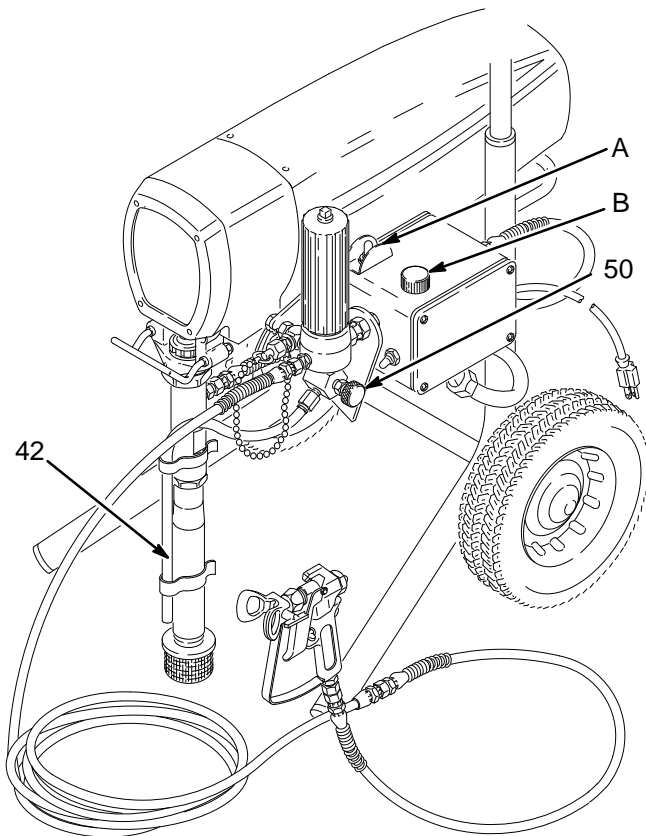


Fig. 1

01888

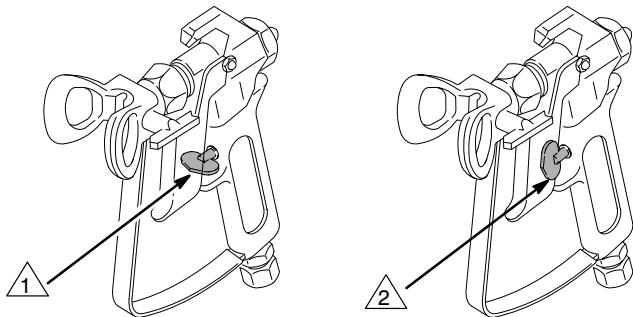
1. **Assemble the gun (106), 3 ft. whip hose (105) and 50 ft. hose (104).** Don't install the spray tip yet.
2. **Two gun hookup.** Remove the cap (12) from the 1/4 npsm(m) secondary hose outlet and attach a minimum 50 ft. long hose. For more flexible gun movement, install a 3/16 in. ID, 3 ft. whip hose between the main hose and the gun.
3. **Fill the packing nut/wet-cup (216)** 1/3 full with Graco Throat Seal Liquid (TSL), supplied.
4. **Check the electrical service.** Be sure the electrical service is 120 V, 60 HzAC. Use a properly grounded outlet. Do not remove the grounding prong of the power supply cord. Do not use an adapter. Extension cords must have 3 wires of a minimum 12 gauge size. Long extension cords reduce sprayer performance.

# Operation

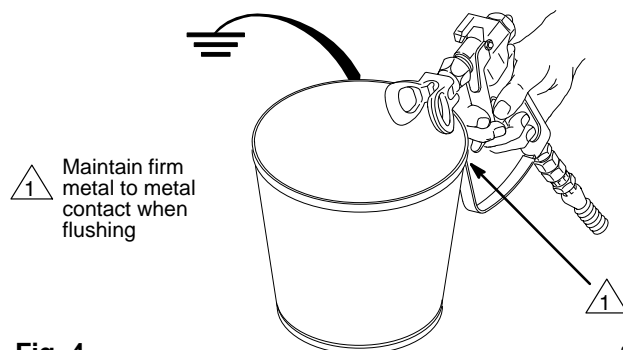


**Fig. 2** 01888

- 1 Gun safety latch shown engaged
- 2 Gun safety latch shown disengaged



**Fig. 3** 0137



**Fig. 4** 0143

## WARNING

To reduce the risk of serious bodily injury, fluid injection, splashing in the eyes or on the skin, or injury from moving parts, always follow the **Pressure Relief Procedure Warning** on page 2 before checking, adjusting, cleaning and shutting down the sprayer.

## Startup

Always use this procedure to help ensure the sprayer is ready to operate and that you start it safely.

1. **For a first time startup**, flush the sprayer. See page 11.
2. **Close the pressure drain valve (50).**
3. **Don't install the spray tip until the pump is primed!**
4. **Put the suction tube (42) into the paint container.**
5. **Lower the pressure setting** by turning the pressure adjusting knob (B) fully counterclockwise.
6. **Disengage the gun safety latch.** See Fig 3.

## CAUTION

Do not run the sprayer dry for more than 30 seconds to avoid damaging the pump packings.

## 7. To prime the pump:

- a. Open the drain valve.
- b. Turn the ON/OFF switch to ON.
- c. Slowly increase the pressure setting until the sprayer starts.
- d. When fluid is flowing from the valve, turn down the pressure and close the valve.
- e. Hold a metal part of the gun firmly against a grounded metal waste container. See Fig. 4.
- f. Trigger the gun and slowly increase the pressure setting until the sprayer starts. Keep the gun triggered until all air is forced out of the system and the paint flows freely from the gun.
- g. Release the trigger and engage the gun safety latch. See Fig 3.

8. **Check all fluid connections for leaks.** If any leaks are found, relieve pressure before tightening the connections.

# Operation

9. **Install the spray tip and tip guard.** Engage the gun safety latch. Install the spray tip. If you are using the RAC IV tip guard, refer to manual 307–848 for installation instructions.
10. **Adjust the pressure.**
  - a. Turn the pressure adjusting knob clockwise just until spray from the gun is completely atomized. To avoid excessive overspray and fogging, and to decrease tip wear and extend the life of the sprayer, always use the lowest possible pressure needed to get the desired results.
  - b. If more coverage is needed, use a larger tip rather than increasing the pressure.
  - c. Test the spray pattern. To adjust the direction of the spray pattern: engage the gun safety latch, loosen the retaining nut, position the tip guard horizontally for a horizontal pattern or vertically for a vertical pattern and tighten the retaining nut.
3. Return the handle to the original position, disengage the gun safety latch, and resume spraying.
4. If the tip is still clogged, engage the gun safety latch, shut off and unplug the sprayer, and open the pressure drain valve to relieve pressure. Clean the spray tip as shown in manual 307–848, supplied with the RAC IV.

## Shutdown and Care

1. **Check the packing nut/wet-cup (216) daily.** Relieve the pressure. Keep the packing nut/wet-cup 1/3 full with TSL at all times to help prevent fluid buildup on the piston rod and premature wear of packings. Tighten the packing nut just enough to stop leakage. Overtightening may cause binding and excessive packing wear. Use a screwdriver and light hammer to adjust the nut. See Fig. 6.
2. **Clean the fluid filter (48) often** and whenever the sprayer is stored. First relieve pressure. See manual 307–273 for the cleaning procedure.
3. **Fill the connecting rod cavity (A) with motor oil** every 100 hours of operation. Relieve pressure first. See Fig. 6.

## Cleaning a Clogged Tip

### WARNING

To reduce the risk of serious bodily injury from fluid injection;

DO NOT hold a hand, body, or rag in front of the spray tip when cleaning or checking it. Always point the gun toward the ground or into a waste container when checking to see if the tip is clear.

DO NOT try to “blow back” paint; this is NOT an air sprayer.

1. If the spray tip does clog, release the gun trigger, engage the gun safety latch, and rotate the RAC IV handle 180°. See Fig. 5.
2. Disengage the gun safety latch and trigger the gun into a waste container. Engage the gun safety latch again.

1 Handle shown in spraying position

2 Gun safety latch shown engaged

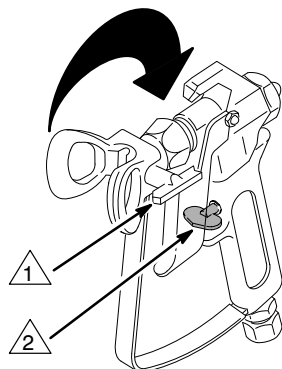


Fig. 5  
10 308–827

0137

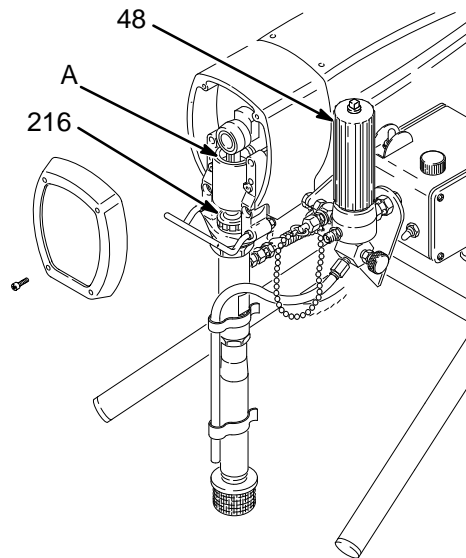


Fig. 6

01892

4. **For very short shutoff periods,** leave the suction tube in the paint, relieve pressure, and clean the spray tip.
5. **Coil the hose and hang it on the hose rack** when storing it, even for overnight, to help protect the hose from kinking, abrasion, coupling damage, etc.

# Flushing

## When to Flush

1. **New Sprayer.** The sprayer was factory tested in lightweight oil which was left in to protect pump parts.  
  
*Before using water–base paint, flush with mineral spirits, then warm, soapy water, and then clean water.*  
  
*Before using oil–base paint, flush with mineral spirits.*
2. **Changing Colors.** Flush with a compatible solvent.
3. **Changing water–base to oil–base paint.** Flush with warm, soapy water, then mineral spirits.
4. **Changing from oil–base to water–base paint.** Flush with mineral spirits, then warm, soapy water, and then clean water.

5. **Storage.** Flush as indicated below, shut off the sprayer, open the pressure drain valve to relieve pressure and leave it open.

*Water–base paint:* flush with water, then mineral spirits. Leave the system filled with mineral spirits.

*Oil–base paint:* flush with mineral spirits.

### CAUTION

Never allow water to freeze in the pressure control. Doing so prevents the sprayer from being started and causes serious damage to the pressure control. Push the water out with mineral spirits.

6. **Startup after storage.** Before using water–base paint, flush out the mineral spirits with soapy water and then clean water. When using oil–base paint, flush out the mineral spirits with the paint to be sprayed.

## How to Flush

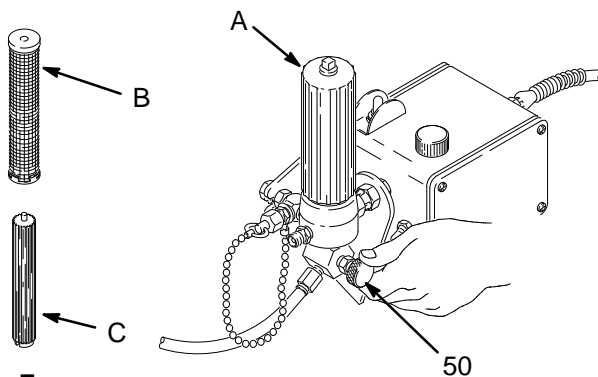


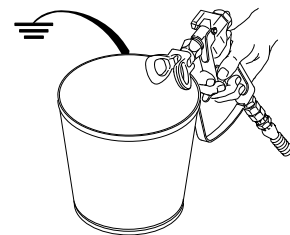
Fig. 7

1. Relieve pressure.
2. Remove the filter bowl (A), support (C) and screen (B); see manual 307–273. Install the bowl and support. Clean the screen separately and install after flushing.. See Fig 7.
3. Close the pressure drain valve.
4. Pour one–half gallon of compatible solvent into a grounded metal pail. Put the suction tube in the pail.
5. Remove the spray tip from the gun, if it is installed.
6. Turn the pressure adjusting knob all the way counterclockwise to lower the pressure setting.

7. Open the drain valve. Turn on the sprayer and increase the pressure until until the sprayer starts. When fluid comes from the valve, close it. Hold a metal part of the gun firmly against a metal waste container. Trigger the gun until all air is forced out of the system and the solvent flows freely from the gun. Release the trigger and engage the gun safety latch.

### WARNING

To reduce the risk of static sparking and splashing when flushing, always remove the spray tip from the gun, and hold a metal part of the gun firmly to the side of grounded metal pail.



0143

8. Remove the suction tube from the pail. Disengage the gun safety latch and trigger the gun to force solvent from the hose. Do not run the pump dry for more than 30 seconds to avoid damaging the pump packings! Relieve pressure.
9. Leave the pressure drain valve open until you are ready to use the sprayer again. If the screen was removed, unscrew the filter bowl and reinstall the clean screen. Reinstall the bowl, hand tight only.
10. If you flushed with mineral spirits and are going to use a water–base paint, flush with soapy water and then clean water. Relieve pressure.

# Troubleshooting

## WARNING

### Pressure Relief Procedure

To reduce the risk of serious bodily injury, including fluid injection, injury from splashing fluid or solvent in the eyes or on the skin, moving parts or electric shock, always follow this procedure whenever you shut off the sprayer, when checking or servicing any part of the spray system, when installing, cleaning or changing spray tips, and whenever you stop spraying.

1. Engage the gun safety latch.
2. Turn the ON/OFF switch to OFF.
3. Unplug the power supply cord.

4. Disengage the gun safety latch. Hold a metal part of the gun firmly to a grounded metal pail. Trigger the gun to relieve pressure.
5. Engage the gun safety latch.
6. Open the pressure drain valve. Leave the pressure drain valve open until you are ready to spray again.

*If you suspect that the spray tip or hose is completely clogged, or that pressure has not been fully relieved after following the steps above, VERY SLOWLY loosen the tip guard retaining nut or hose end coupling to relieve pressure gradually, then loosen completely. Now clear the tip or hose obstruction.*

Check everything in the guide before disassembling the sprayer.

TYPE OF PROBLEM	WHAT TO CHECK <i>If check is OK, go to next check</i>	WHAT TO DO <i>When check is not OK refer to this column</i>
Building circuit breaker opens	Check all electrical wiring for damaged insulation.	Replace any damaged wiring.
	Check for other electrical appliances on circuit.	Shutdown other electrical appliances on circuit.
	Check position of 15–20 (Lo–High) amp switch.	Put switch in 15 amp (LO) position.
Sprayer circuit breaker opens	Check for located motor rotor. Unplug cord and try to turn fan blades with a screwdriver.	Repair gear train or pump, if damaged. Thaw the sprayer, if frozen; See NOTE 1. Replace the pressure control, if damaged.
	Check for shorted motor. Use ohmmeter to check for shorts between motor leads or between motor leads and motor frame.	Inspect for damage to motor brush leads. Replace motor, if necessary.
	Check electrical supply with voltmeter. Meter should read 105–125 VAC.	Connect to outlet of correct voltage.
Sprayer will not run	Check pressure control knob setting. Motor will not run if it is at minimum setting (fully counterclockwise).	Slowly increase pressure setting to see if motor starts.
	Check for a clogged spray tip. Refer to separate gun or tip instruction manual.	Relieve pressure. Refer to separate gun or tip instruction manual for tip cleaning.
	Check extension cord for visible damage. Use a volt meter or test lamp at extension cord outlet to check.	Replace extension cord.
	Check sprayer power supply cord for visible damage such as broken insulation or wires.	Replace power supply cord.
	Check electrical supply with volt meter. Meter should read 105–125 VAC.	Reset building circuit breaker; replace building fuse. Try another outlet.
	Check for motor damage. Remove drive housing assembly. See page 23. Try to rotate fan by hand.	Replace motor (1) if fan won't turn.
Poor spray pattern	Check for worn spray tip.	Relieve pressure and then replace the tip. See the separate gun or tip manual.

# Troubleshooting

TYPE OF PROBLEM	WHAT TO CHECK <i>If check is OK, go to next check</i>	WHAT TO DO <i>When check is not OK refer to this column</i>
Motor runs and pump strokes, but output is low or there is no output.	Check extension cord size and length.	Replace cord with a larger size, grounding type extension cord.
	Check paint supply.	Refill and reprime pump.
	Check for clogged intake strainer.	Remove and clean strainer and reinstall.
	Check for loose suction tube or loose fittings.	Tighten; use thread sealant or sealing tape on threads, if necessary.
	Check for worn spray tip.	Follow <b>Pressure Relief Procedure Warning</b> , then replace tip. See your separate gun or tip manual.
	Check motor brushes; check for loose leads and terminals, minimum 1/2" brush length, broken or misaligned springs, or brushes binding in holders. See page 14.	Replace parts as needed. See page 14.
	Check motor armature for shorts by using an armature tester (growler).	Replace motor. See page 19.
	Check to see if pump continues to stroke when gun trigger is released. With pump on and primed, trigger gun momentarily, then release and engage safety latch. Relieve pressure, turn off and unplug sprayer.	Service pump. See page 15.
	Check to see if intake valve ball and piston ball are seating properly.	Remove intake valve and clean. Check balls and seats for nicks; replace if necessary. See page 16. Strain paint before using to remove particles that could clog the pump.
	Check for leaking around throat packing nut which may indicate worn or damaged packings.	Replace packings. See page 15. Also check piston valve seat for hardened paint or nicks and replace if necessary. Tighten the packing nut/wetcup.
Motor runs but pump does not stroke.	Check displacement pump connecting rod pin (20). See page 19.	Replace pin, if missing. Be sure retainer spring (35) is fully in groove all around connecting rod. See Fig. 38, page 19.
	Check for frozen or hardened paint in the pump (39).	Thaw. See NOTE 1. Plug in sprayer and turn on. Slowly increase pressure setting to see if motor starts.
	Be sure crank in drive housing rotates; plug in sprayer and turn on briefly to check. Turn off and unplug sprayer.	Check drive housing assembly for damage and replace if necessary. See page 23.
Motor is hot and runs intermittently.	Determine if sprayer was operated at high pressure with small tips, which causes low motor RPM and excessive heat build up.	Decrease pressure setting or increase tip size.
	Be sure ambient temperature where sprayer is located is no more than 90°F and sprayer is not located in direct sun.	Move sprayer to shaded, cooler area, if possible.
	Determine if sprayer was turned on, pressurized, but not operating for long periods of time.	Turn off sprayer whenever you stop spraying for a while and relieve fluid pressure.

**NOTE 1:** Thaw the sprayer if water or water-based paint has frozen in it, by placing it in a warm area. Do not try to start the sprayer until it has thawed completely. If paint hardened (dried) in the sprayer, replace the pump packings. See page 15.

# Motor Brush Replacement

**NOTE:** Replace the brushes when they have worn to about 0.4 in (10 mm). Always check both brushes and replace them together. A Brush Repair Kit, p/n 220-853, and the spring clip, p/n 110-816, are available. Order separately.

**NOTE:** Replacement brushes may last only half as long as the original ones. To maximize brush life, break in new brushes by operating the sprayer for at least one hour with no load (remove the pump connecting rod pin).

## WARNING

Follow the **Pressure Relief Procedure Warning** on page 2 to reduce the risk of a fluid injection injury, splashing in the eyes or on the skin, injury from moving parts, or electric shock.

1. Remove the motor cover (14) and both inspection covers (A). See Fig 8.
2. Push in the spring clip (D) to unhook it, and then pull it out. See Fig 9.
3. Loosen the terminal screw (F). Pull the brush lead (G) away, leaving the motor lead in place. Remove the brush (C) and spring (B). See Fig 10.
4. Inspect the commutator for excessive pitting, burning or gouging. A black color on the commutator is normal. Have the commutator resurfaced by a qualified motor repair shop if the brushes seem to wear too fast.
5. Install the new brush (C) so its lead is in the long slot (K) of the holder (H). Slide the terminal (E) under the terminal screw (F) washer. Make sure the motor lead terminal (G) is still connected at the screw. Tighten the screw. See Fig 11.
6. Place the spring (A) on the brush (C) as shown in Fig 11.
7. Push in and hook the spring clip (D). See Fig 11.
8. Repeat for the other side.

## CAUTION

Do not run the sprayer dry for more than 30 seconds while checking the brushes to avoid damaging the displacement pump.

9. Reinstall the remaining parts.

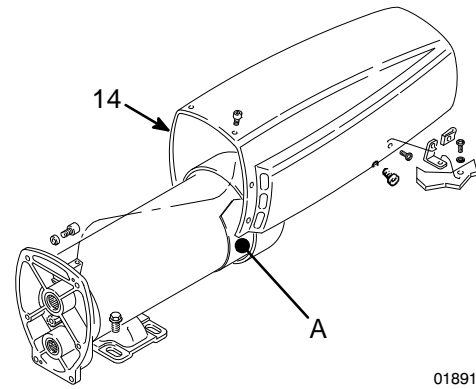


Fig. 8

01891

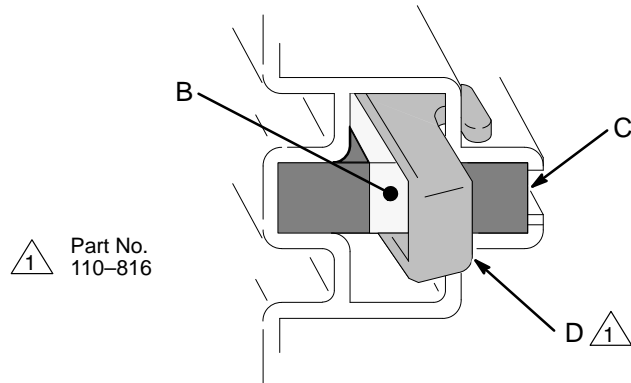


Fig. 9

Part No.  
110-816

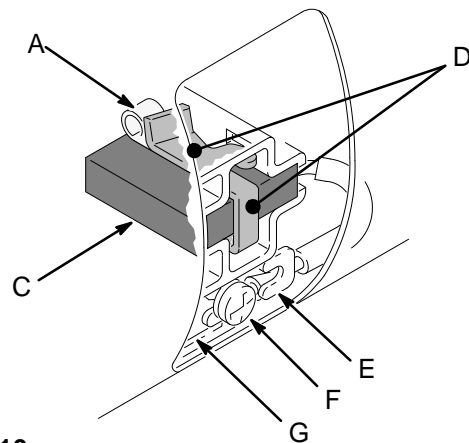


Fig. 10

2 Note: Spring must coil in this direction

3 Minimum brush length: 0.4 in. (10 mm)

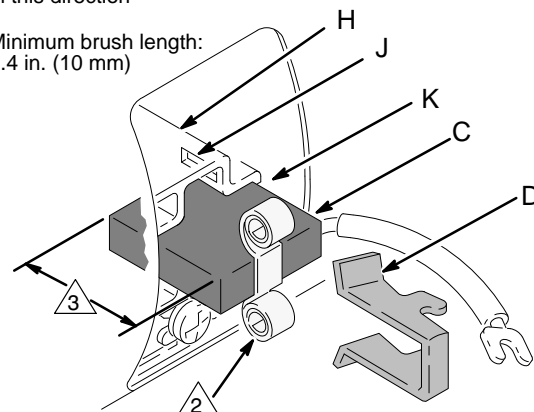


Fig. 11

01227

# Displacement Pump Repair

## Removing the Pump

### WARNING

Follow the **Pressure Relief Procedure Warning** on page 2 to reduce the risk of a fluid injection injury, splashing in the eyes or on the skin, injury from moving parts or electric shock.

**NOTE:** Some parts shown Figures 12 to 15 may look somewhat different from your sprayer.

1. Flush the pump, if possible, and relieve pressure again. Stop the pump with the piston rod in its lowest position, if possible.
2. Remove the hose (47), clips and drain tube (101). Remove the suction tube (42); hold the wrench on the pump intake valve (223) to keep the pump from loosening. See Fig. 12.
3. Push the retaining spring (35) up. See Fig. 13.
4. Push out the pin (20). See Fig. 14.
5. Loosen the locknut (38) and unscrew the pump from the bearing housing (27). See Fig. 15.

## Tools Needed for Pump Repair

Repair Kit, P/N 220-877  
Sleeve Removal Tool, P/N 220-991  
Heavy duty vise  
1-1/16" open end wrench for Pump 220-872  
2-1/4" adjustable, open-end wrench  
Plastic mallet  
Small screwdriver  
Throat Seal Liquid  
Thread Sealant

**NOTE:** Soak leather packings in oil before using.

## Cleaning and Inspecting Parts

Clean and inspect the parts. Pay particular attention to the ball seat in the intake valve, which should have no nicks or wear, and to the inside of the sleeve and the outside of the piston rod, which should not be worn or scratched. Replace worn or damaged parts.

Remove and clean the sleeve when you are repacking the pump. A special sleeve removal tool is available. See the chart, above, for the tool number for your pump.

### WARNING

Always use the special sleeve removal tool to remove the sleeve. Other removal methods could cause the pump to rupture, resulting in serious bodily injury. If the sleeve cannot be removed easily using the tool, return the sleeve and cylinder to your Graco distributor for removal.

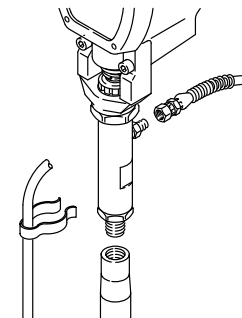


Fig. 12

02553

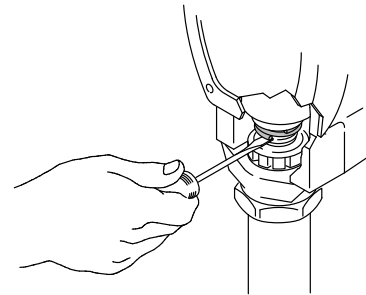


Fig. 13

02554

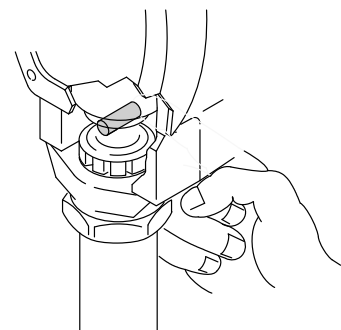


Fig. 14

02555

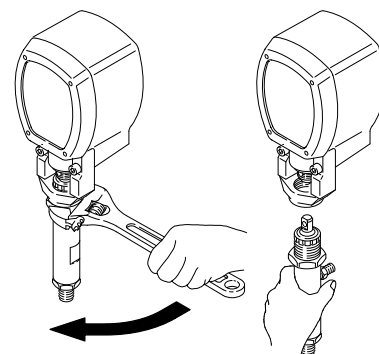


Fig. 15

02556

# Displacement Pump Repair

## Disassembly

**NOTE:** Parts included in the Packing Repair Kit, P/N 220–877, are marked with an asterisk (\*) in the text and drawings. Use all the new parts in the kit.

1. Loosen the packing nut (16) and plug (5). Unscrew the cylinder from the intake valve. See Fig. 16.
2. Disassemble the intake valve. Use a pick to remove the old gasket (202). Clean and inspect the parts. See Fig. 17.
3. Reassemble the intake valve using a new gasket (\*202\*), ball (\*204\*) and pin (\*221\*). See Fig. 17.
4. Tap the piston rod (224) out of the cylinder. See Fig. 18.
5. Screw the sleeve removal tool's large nut (A) into the top of the cylinder. Screw down the rod to push the sleeve out. See Fig. 19. Remove the tool. Clean and inspect the parts.
6. Clamp the piston rod (224) in a vise. Loosen the retaining nut (211). Unscrew the piston valve (222). See Fig. 20.
7. Disassemble the piston and discard the packings and glands. See Fig. 21.
8. Remove and discard the throat packings and glands. See Fig. 22.

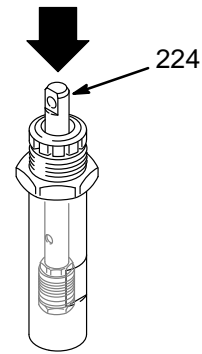


Fig. 18

02561

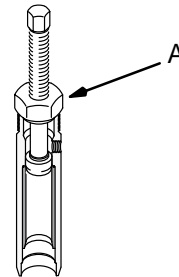


Fig. 19

02562

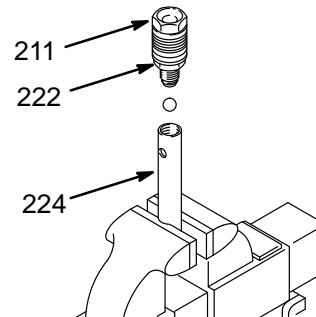


Fig. 20

02563

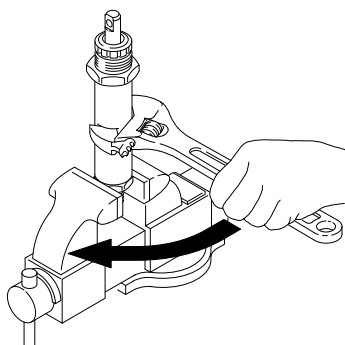


Fig. 16

02558

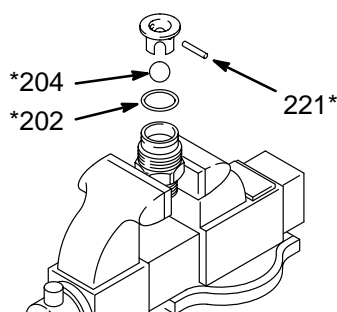


Fig. 17

02559

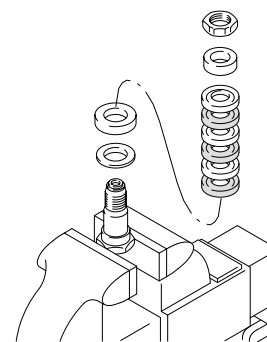


Fig. 21

02564

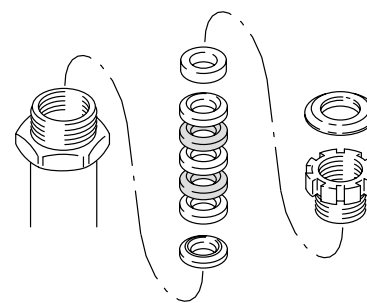


Fig. 22

02565

# Displacement Pump Repair

## Pump Reassembly

1. Clean the piston valve threads. One at a time, stack the backup washer (203\*), seal (215\*) (with lips facing down), and female gland (214\*) on the piston. Alternately stack the polyethylene (212\*) and leather (206\*) packings (lips facing up) on the piston. Then install the male gland (210\*). See Fig. 23.
2. Place the flats of the piston valve in a vise. Tighten the packing retaining nut against the piston valve to 4 in-lb (0.35 N.m). See Fig. 24.

**Note the alignment** of the piston to the packing retainer nut. Maintain this alignment through Steps 4 and 5.

3. Apply one drop of Loctite to the threads. Place the ball (225\*) on the piston valve. See Fig. 25.
4. While maintaining the alignment, thread the piston valve assembly into the piston rod just until the piston valve nut contacts the rod. See Fig. 26.
5. Place the flats of the rod in a vise. Carefully tighten the piston valve nut (211) against the piston rod to 19 ft-lb (27 N.m). Use two wrenches to maintain the alignment. See Fig. 27.
6. Place the male gland (208\*) in the cylinder. Alternately stack the polyethylene (213\*) and leather packings (207\*) (lips facing down). Then place the female gland (209\*) in the top of the cylinder. Seat the packings. See Fig. 28.

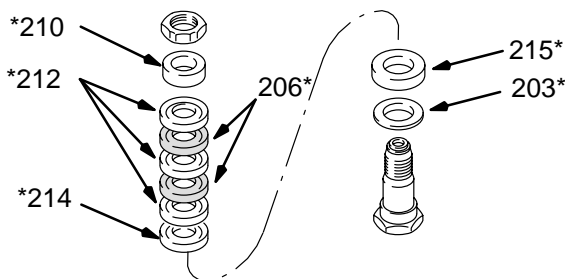


Fig. 23 02566

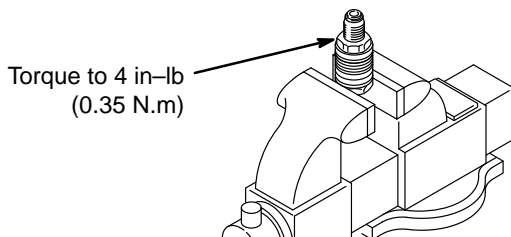


Fig. 24 02567

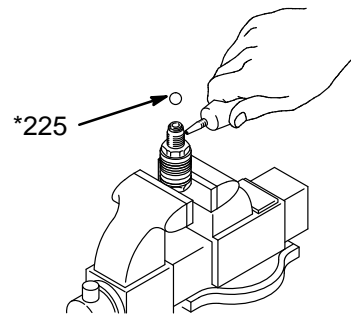


Fig. 25 02568

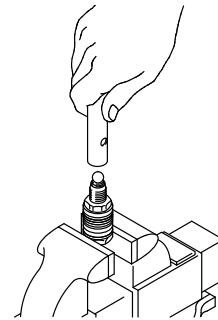


Fig. 26 02569

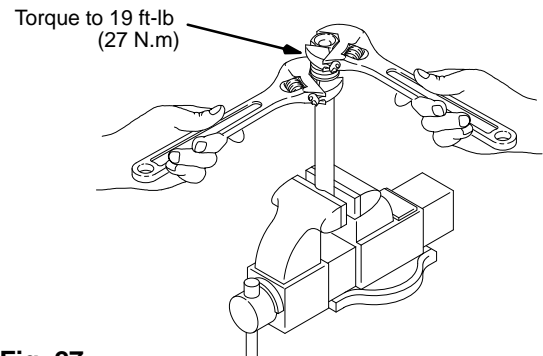


Fig. 27 02570

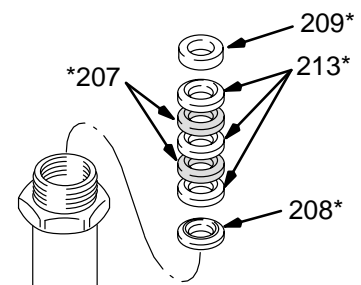


Fig. 28 02571

# Displacement Pump Repair

- Loosely install the packing nut and plug. See Fig. 29.
- Place a o-ring (17\*) in the cylinder. Slide the sleeve in to the cylinder to seat the o-ring. See Fig. 30. Remove the sleeve.
- Grease the piston packings and the top edge of the sleeve. See Fig. 31.
- Carefully slide the piston assembly into the top of the sleeve. See Fig. 32.
- Slide the sleeve/piston rod assembly into the bottom of the cylinder. See Fig. 33.
- Grease the intake valve o-ring with non-silicon grease. Screw the pump cylinder into the intake valve. Torque to 70 ft-lb (95 N.m). See Fig. 34.
- Tighten the packing nut (216) hand tight. Screw the cylinder locknut (A) down to the bottom of the external cylinder threads. See Fig. 35.

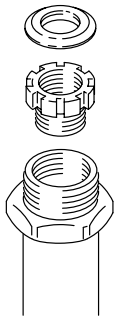


Fig. 29 02572

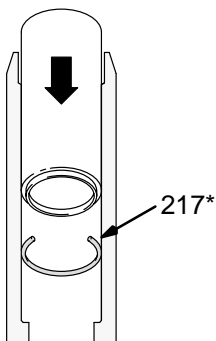


Fig. 30 02573

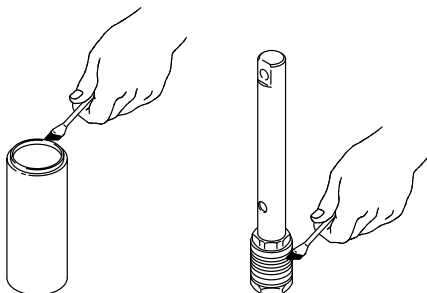


Fig. 31 02574

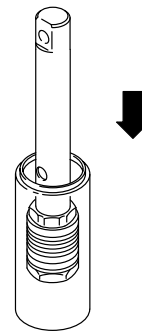


Fig. 32 02575

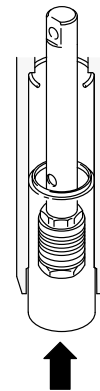


Fig. 33 02576

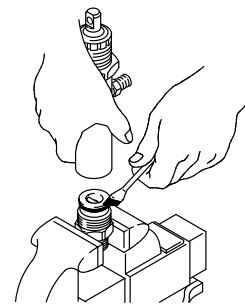


Fig. 34 02577

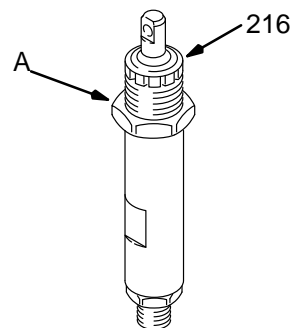


Fig. 35 02578

# Displacement Pump Repair

## Installing the Pump

**NOTE:** Some parts in Figures 36 to 40 may look somewhat different than your sprayer.

1. Screw the displacement pump into the bearing housing (27) until the pin holes align. See Fig. 36.
2. Install the pin (221\*). See Fig. 37.
3. Continue to screw the pump into the bearing housing until the top threads of the pump cylinder are flush with the face of the bearing housing and the outlet nipple is straight back. Push the retaining spring (35) into the groove all the way around the connecting rod to prevent it from working loose due to vibration. See Fig. 38.

### WARNING

If the pin works loose, it or other parts could break off due to the force of the pumping action. These parts could be projected through the air and result in serious bodily injury or property damage, including damage to the pump, connecting rod or bearing housing.

4. Tighten the locknut (38) to 70 ft-lb (97 N.m). See Fig. 39.

### CAUTION

If the locknut (38) loosens during operation, the threads of the bearing housing (29) will be damaged. Be sure to tighten the locknut firmly.

5. Tighten the packing nut/ wet-cup just enough to stop leakage, but no tighter. Fill the wet-cup/packing nut 1/3 full with Graco TSL. See Fig. 40.

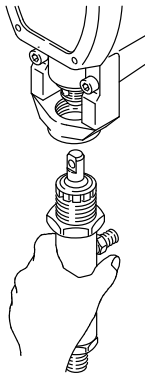


Fig. 36

02579

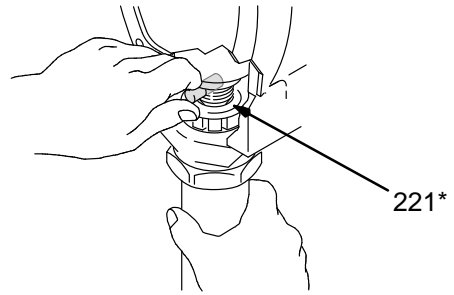


Fig. 37

02580

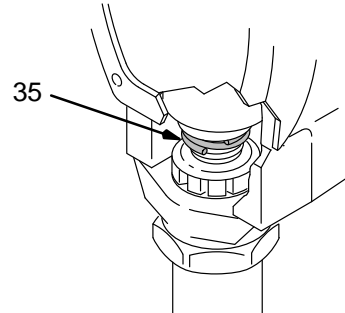


Fig. 38

02581

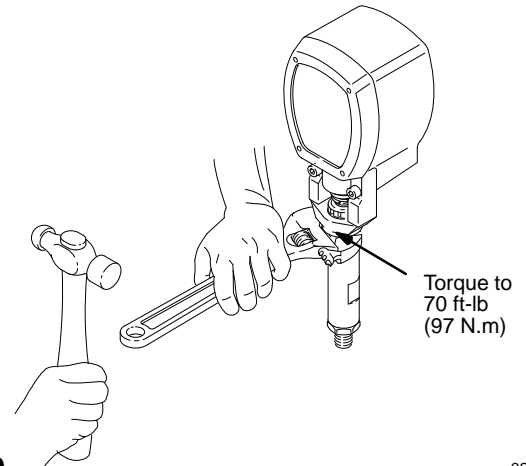


Fig. 39

02582

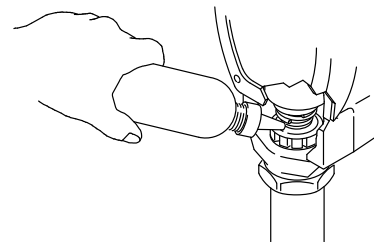


Fig. 40

02583

# Pressure Control Replacement

## WARNING

Follow the **Pressure Relief Procedure Warning** on page 2 to reduce the risk of a fluid injection injury, splashing in the eyes or on the skin, injury from moving parts, or electric shock.

**NOTE:** Refer to Fig. 41 except where noted.

1. Disconnect the hose (47).
2. Disconnect the drain tube (101) from the drain valve.
3. Loosen the outside filter bracket nut (28). Unscrew the fitting (8) and remove the filter.
4. Remove the pressure control cover (36). Disconnect the four motor leads. See Fig. 42.
5. Unscrew the connector (54). Pull the wires out of the pressure control.
6. Remove the pressure control mounting screws (37). Remove the pressure control. Install the connector (54) on the new pressure control.
7. Install the new pressure control. Place the seal (103) around the motor leads and push the seal into the connector (54).

# Power Supply Cord

**NOTE:** Refer to Fig. 41 except where noted.

1. Remove the back pressure control plate (16).
2. Remove the pressure control cover. Disconnect the power supply cord leads. See Fig. 42.
3. Loosen the strain relief bushing (B). Remove the power supply cord (23).
4. Install the new cord.

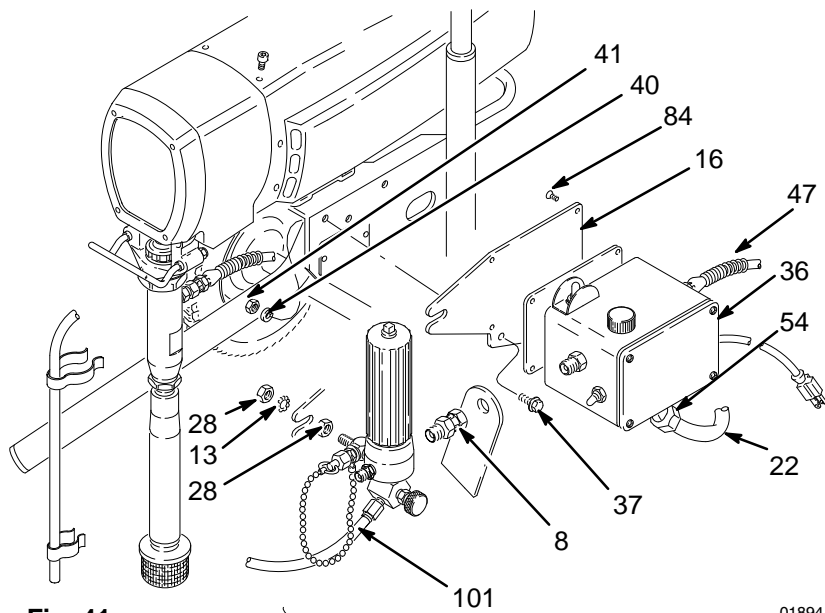
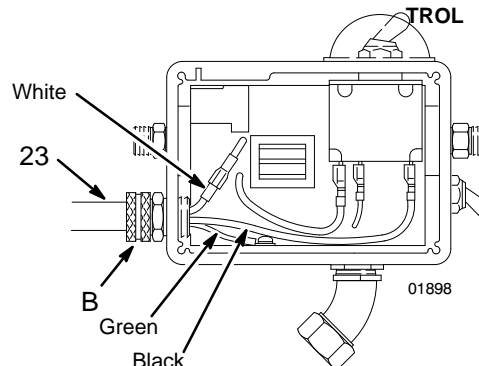


Fig. 41

01894

## BACK VIEW OF PRESSURE CONTROL



## FRONT VIEW OF PRESSURE CONTROL

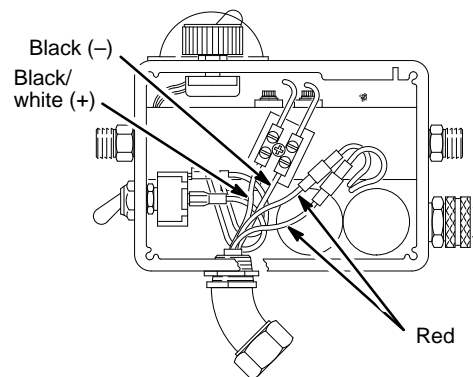


Fig. 42

01897

# Motor Replacement

## WARNING

Follow the **Pressure Relief Procedure Warning** on page 2 to reduce the risk of a fluid injection injury, splashing in the eyes or in the skin, injury from moving parts or electric shock.

## CAUTION

To avoid damage to the drive housing:

- Do not drop the gear cluster (9), which may stay engaged in the motor bell or in the drive housing.
- Do not lose the thrust balls (10) or drop them between gears. The balls usually stay in the shaft recesses, but could be dislodged. If the balls are not in place, the bearings will wear prematurely.

1. Remove the motor shield (14). Remove the front cover (31). Disconnect the hose (47).
2. Remove the pressure control cover (36). Disconnect the four motor leads.
3. Unscrew the connector (54) from the pressure control. Pull the wires through the connector.
4. Unscrew the connector (54) from the motor and remove the conduit (22).
5. Remove the screws (51) from the recess of the drive housing.
6. Remove the screws (21 and 30) from the the motor bell (F).
7. Use a plastic mallet to tap the displacement pump (39) from the rear to loosen the drive housing (18) from the motor bell (F). Pull off the drive housing.
8. Remove the screws (37) holding the motor to the frame. Lift off the motor.
9. Mount the new motor on the frame.
10. Slide a connector (54) over the conduit (22) of the new motor and screw two or three threads of it into the motor. Tighten the locknut (44) up to the motor.
11. Liberally grease the gear cluster (9) and pinion gear (G) and pack all bearings in the motor bell. Be sure the thrust balls (10) are in place. (One ball is included with a replacement drive housing.)
12. Place the bronze-colored washer (18b) and THEN the silver-colored washer (18a) on the shaft protruding from the big gear in the drive housing (18).
13. Align the gears and push the drive housing (18) straight onto the motor bell (F) and locating pins.
14. Continue to reassemble the sprayer.

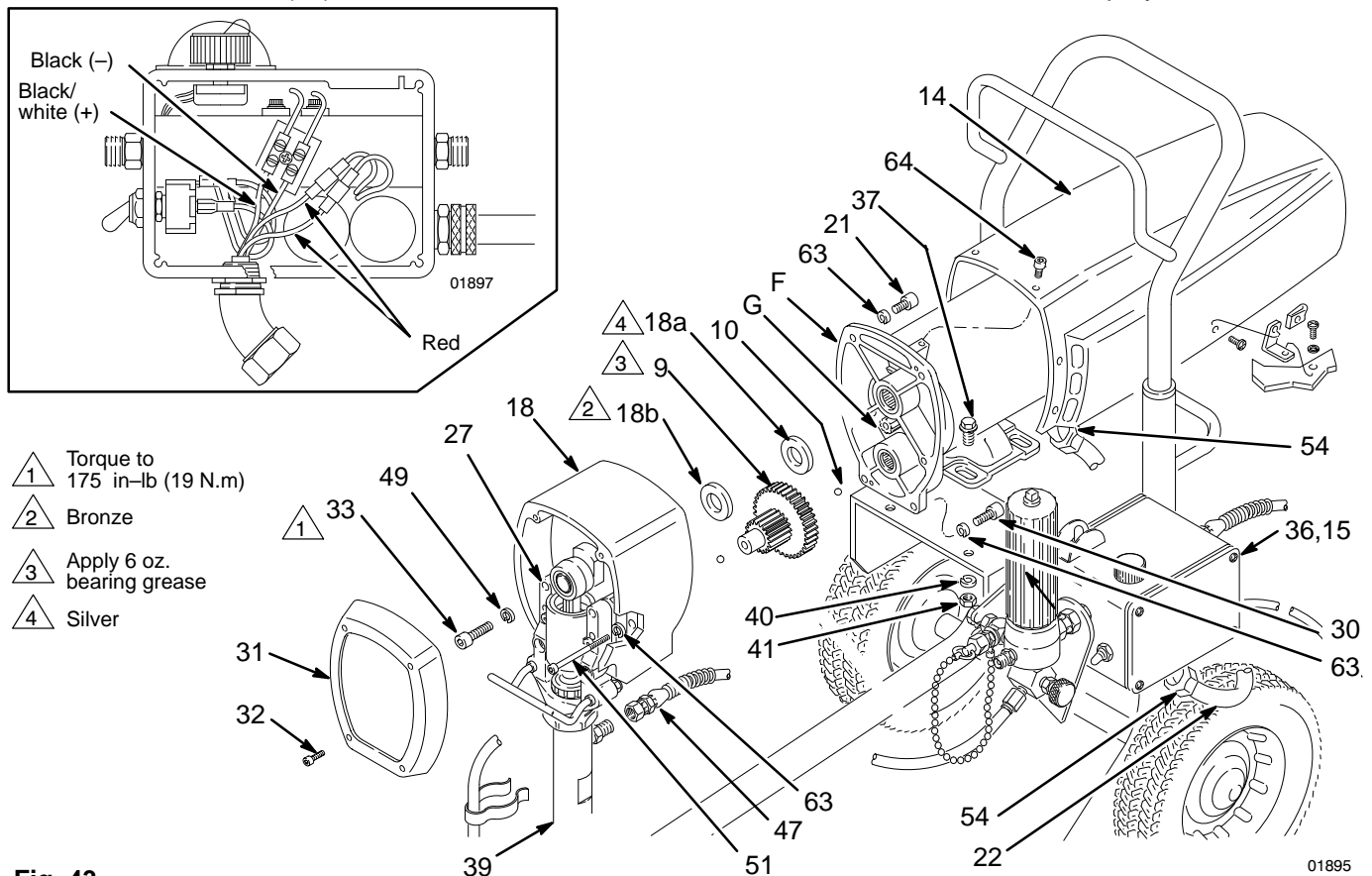


Fig. 43

# Bearing Housing & Connecting Rod Replacement

## WARNING

Follow the **Pressure Relief Procedure Warning** on page 2 to reduce the risk of a fluid injection injury, splashing in the eyes or in the skin, injury from moving parts or electric shock.

- 1 Torque to 175 in-lb (19 N.m)
- 2 Lubricate with motor oil
- 3 Liberally pack roller bearing with bearing grease

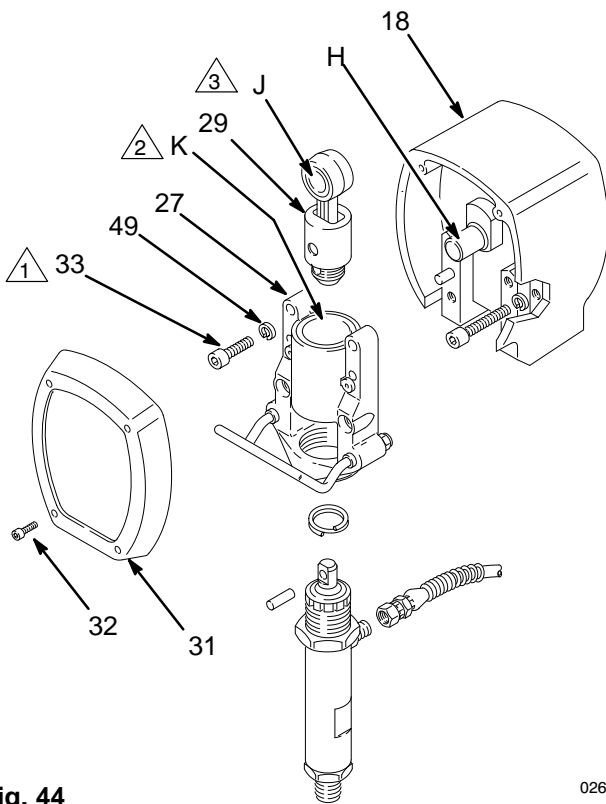


Fig. 44

02654

**NOTE:** Stop the sprayer at the bottom of its stroke to get the crank (H) in its lowest position. To lower the crank manually, rotate the blades of the motor fan with a screwdriver.

1. Remove the pump. See page 15.
2. Remove the front cover (31). Remove the bearing housing screws (33).
3. Tap the lower rear of the bearing housing (27) with a plastic mallet to loosen it from the drive housing (18). Pull the bearing housing and the connecting rod (29) straight off the drive housing.
4. Inspect the crank (H) for excessive wear and replace parts as needed.
5. Evenly lubricate the inside of the bronze bearing (K) with motor oil. Liberally pack the roller bearing (J) with bearing grease.
6. Assemble the connecting rod (29) and bearing housing (27).
7. Clean the mating surfaces of the bearing and drive housings.
8. Align the connecting rod with the crank (H) and align the locating pins in the drive housing with the holes in the bearing housing (27). Push the bearing housing onto the drive housing or tap it into place with a plastic mallet.
9. Install the bearing housing screws (33). Torque evenly to 175 in-lb (19 N.m).
10. Reinstall all parts. See page 19 to install the pump.

# Drive Housing Replacement

## WARNING

Follow the **Pressure Relief Procedure Warning** on page 2 to reduce the risk of a fluid injection injury, splashing in the eyes or in the skin, injury from moving parts or electric shock.

**NOTE:** Stop the sprayer at the bottom of its stroke to get the crank (H) in its lowest position. To lower it manually, carefully rotate the blades of the fan with a screwdriver.

1. Remove the front cover (31). Remove the motor shield (14).
2. Disconnect the pump outlet hose (47).
3. Remove the screws (33) from the bearing housing.
4. Lightly tap the lower rear of the bearing housing (27) with a plastic mallet to loosen it from the drive housing (18). Pull the bearing housing and connecting rod assembly straight off the drive housing.
5. Remove the screws (51) from the recess of the drive housing.
6. Remove the screws (30 and 21) from the motor bell (F).

7. Tap the drive housing (18) with a plastic mallet to loosen it from the motor bell, then pull it straight off.

## CAUTION

To avoid damage to the drive housing:

- Do not drop the gear cluster (9), which may stay engaged in the motor bell or in the drive housing.
  - Do not lose the thrust balls (10) or drop them between gears. The balls usually stay in the shaft recesses, but could be dislodged. If the balls are not in place, the bearings will wear prematurely.
8. Use approximately 6 oz. of the bearing grease supplied with the drive housing replacement kit to grease the gear cluster (9). Check to be sure the thrust balls (10) are in place.
  9. Place the bronze-colored washer (18b) and THEN the silver-colored washer (18a) on the shaft protruding from the big gear in the drive housing (18).
  10. Align the gears and push the new drive housing straight onto the motor bell and locating pins.
  11. Continue to reassemble the sprayer. Torque the screws (33) to 175 in-lb (19 N.m).

- 1 Torque to 175 in-lb (19 N.m)
- 2 Bronze
- 3 Apply 6 oz. bearing grease
- 4 Silver

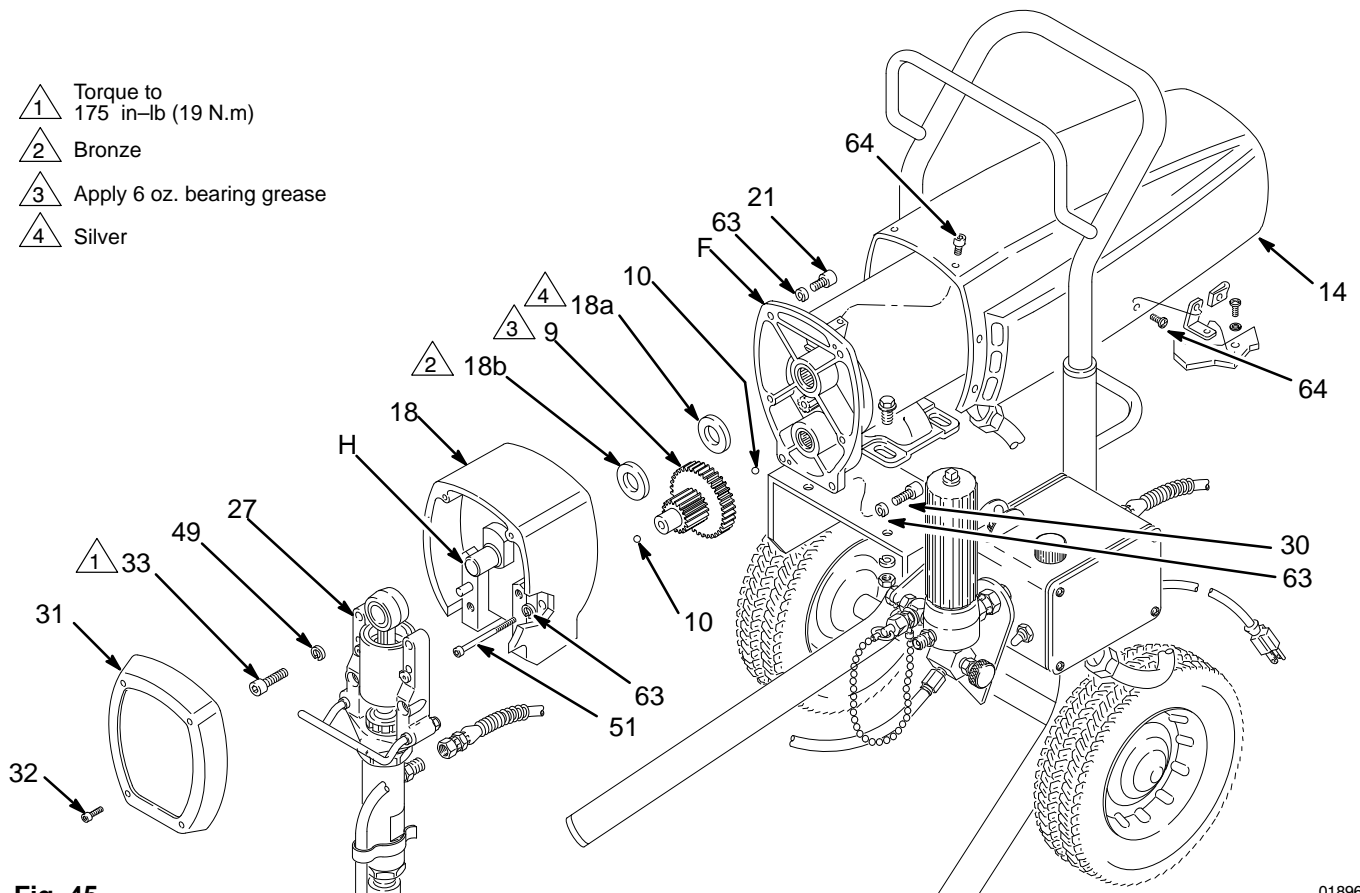
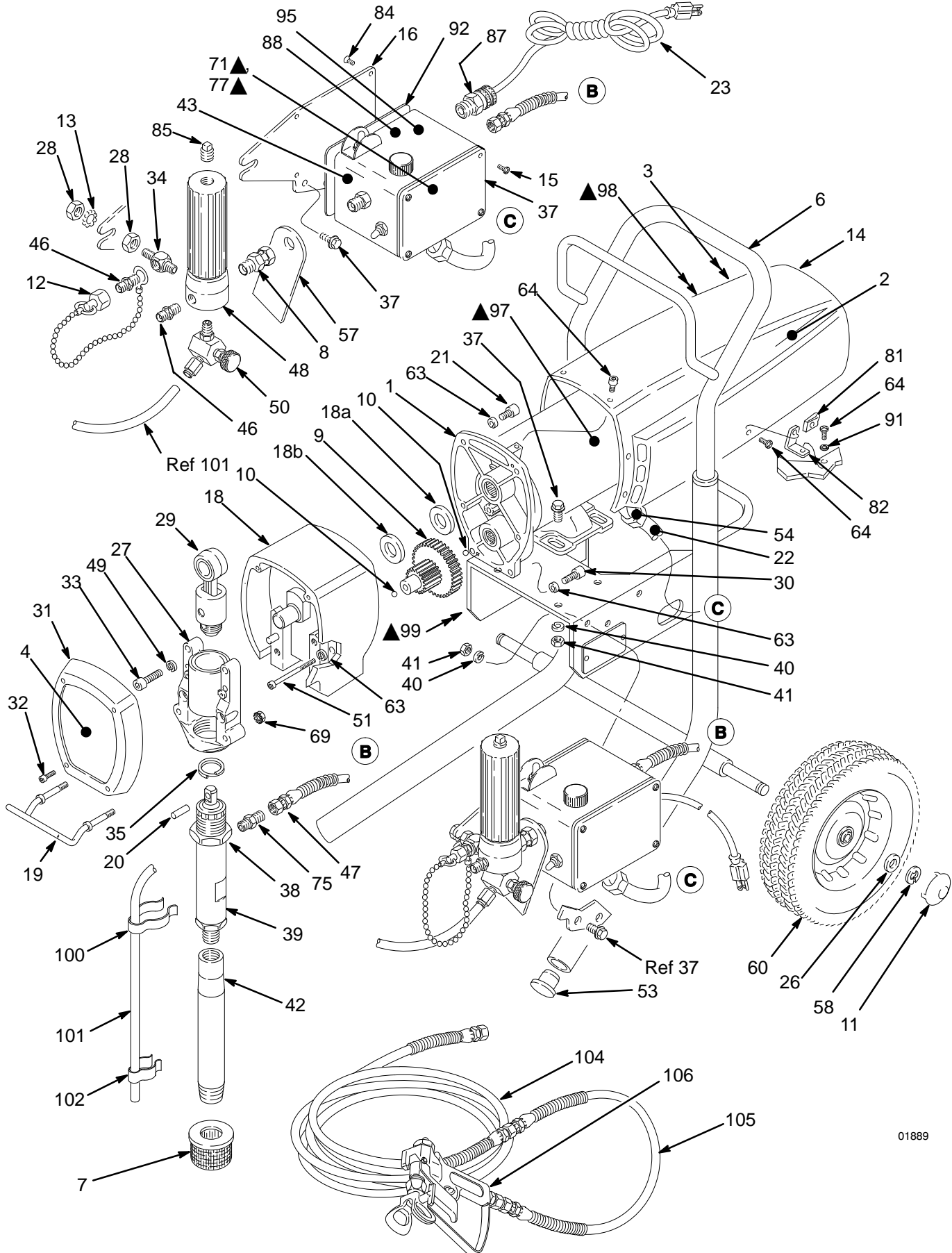


Fig. 45

01896

# Parts



01889

# Parts

## Model 220–627, Series B

Basic Sprayer, Includes items 1–103

## Model 231–053

Complete Sprayer, Includes items 1 – 106

## Model 223–773, Series A

Basic Sprayer, CSA certified, Includes items 1–103

### Ref.

Ref. No.	Part No.	Description	Qty.	Ref. No.	Part No.	Description	Qty.
1**	220–854	MOTOR KIT <i>Includes 1 of item 92</i>	1	49	106–115	NIPPLE, hex; 1/4 npsm x 1/4 npt, 1–3/16" long	2
2	183–196	LABEL, identification, motor cover	1	50	221–077	HOSE, 3/8 npsm(f) x 14–1/2"	1
3	183–197	LABEL, identification, motor cover	1	51	108–849	FLUID FILTER <i>see manual 307–273 for parts</i>	1
4	183–198	LABEL, identification, front cover	1	53	108–849	LOCKWASHER, spring; 3/8"	4
6	220–636	CART	1	54	108–691	PRESSURE DRAIN VALVE	1
7	187–147	STRAINER	1	56	108–460	CAPSCREW, sch; 1/4–20 x 3"	2
8	155–665	UNION, adapter; 3/8" npsm swivel x 3/8 npt(m)	1	57▲	102–556	PLUG, tubing	2
9	220–637	GEAR REDUCER	1	58	178–034	CONNECTOR	2
10	100–069	BALL, steel; 1/4" dia.	1	59	101–242	RIVET, blind; 1/8" dia.	2
11	104–811	HUBCAP	2	60	206–994	TAG, WARNING	1
12	220–285	CAP	1	63	179–811	RING, retaining	2
13	100–322	LOCKWASHER, ext., 7/16"	1	64	105–510	THROAT SEAL LIQUID 8 oz. (0.27 liter)	1
14	223–153	MOTOR SHIELD KIT	1	69	108–865	WHEEL	2
15	110–037	SCREW, pnh; 10–24 type C x 1/2"	4	71▲	110–814	LOCKWASHER, spring, 1/4"	6
16	185–539	BRACKET, mounting	1	75	177–762	SCREW, pnh; 8–32 x 3/8"	10
18	220–879	DRIVE HOUSING KIT <i>Includes items 18 a and 18b, 1 of 10</i>	1	77▲	183–461	NUT, retainer	2
18a	183–209	.BEARING, thrust	1	81	181–608	LABEL, WARNING	1
18b	106–227	.SPACER	1	82	185–384	ADAPTER; 3/8 npsm x 1/4 npt	1
19	186–227	HANGER, pail	1	84	110–240	LABEL, WARNING	1
20	183–210	PIN, straight, 3/8 x 1–1/8"	1	85	106–078	BRACKET	2
21	100–644	SCREW, soc head, no. 1/4–20 x 3/4"	2	87	106–040	NUT	2
22	065–099	CONDUIT, electrical <i>specify length when ordering</i>	11–5/8 in.	88	100–040	SCREW, flat hd; 10–24 x 3/8"	4
23		POWER SUPPLY CORD		89	100–035	PLUG	1
	223–858	For Models 220–627, 231–053	1	90	157–021	BUSHING, strain relief	1
	223–933	For Model 223–773	1	91	100–020	LABEL, control	1
24	107–264	TERMINAL, female	2	92	187–656	SCREW, pnh; 8–32 x 5/16"	1
26	154–636	WASHER	2	93	157–021	LOCKWASHER, internal, No. 8 <i>inside pressure control</i>	1
27	220–639	BEARING HOUSING KIT	1	97▲	100–020	LOCKWASHER, 0.194" ID	2
28	150–513	NUT, jam; 7/16"	2	98▲	187–656	GASKET	2
29	220–640	CONNECTING ROD KIT	1	99▲	110–619	LABEL, Caution	1
30	100–643	SCREW, socket head, no. 1/4–20 x 1"	2	100	178–035	LABEL, Caution	1
31	183–168	COVER, housing	1	101	185–951	LABEL, DANGER	1
32	108–850	SCREW, filh; no. 8–32 x 1–1/4"	4	102	185–952	LABEL, DANGER	2
33	110–141	CAPSCREW, sch; 3/8–16 x 1–1/5"	4	103	185–955	LABEL, DANGER	1
34	186–374	ADAPTER, elbow, special; 1/4–18 npt(m x f)	1	104	186–490	LABEL, DANGER	1
35	183–169	SPRING, retaining	1	105	186–495	CLIP, spring	1
36	185–000	COVER, pressure control	1	106	186–495	TUBE, drain	1
37	110–963	CAPSCREW, flange head, 5/16–18 x 3/4"	7	107	181–102	CLIP, spring	1
38	183–170	NUT, hex, 1 13/16 unc–2b	1	106	107–447	SEAL	2
39	220–872	DISPLACEMENT PUMP <i>see page 26</i>	1	104	223–541	HOSE, grounded, nylon; 1/4" ID; cpld 1/4 npsm(f); 50 ft (15 m); spring guards both ends	1
40	100–214	LOCKWASHER, spring; 5/16"	7	105	214–701	HOSE, grounded, nylon; 3/16" ID; cpld 1/4 npsm(f); 3 ft. (9 m); spring guards both ends	1
41	100–188	NUT, heavy hex; 5/16–18 unc–2a	7	106	220–955	SPRAY GUN	1
42	183–423	TUBE, INTAKE	1	107	112–152	CIRCUIT BREAKER, 120V <i>see manual 307–614 for parts</i>	1
43		PRESSURE CONTROL KIT <i>includes items 13, 16, 23, 2 of 28, 34, 23, 4 of 84</i>				not shown–located at the back inside of the pressure control, Ref. No. 43, and just below the toggle switch	1
	223–803	NEW KIT, for Models 220–627 & 231–053	1	▲		<b>Replacement Danger and Warning labels, tags and cards are available at no cost.</b>	
	223–804	REBUILT KIT, for Models 220–627 & 231–053	1	**		<b>There is a Motor Brush repair kit, P/N 220–853, available for this motor.</b>	
	224–018	NEW KIT, for Model 223–773	1				

# Parts

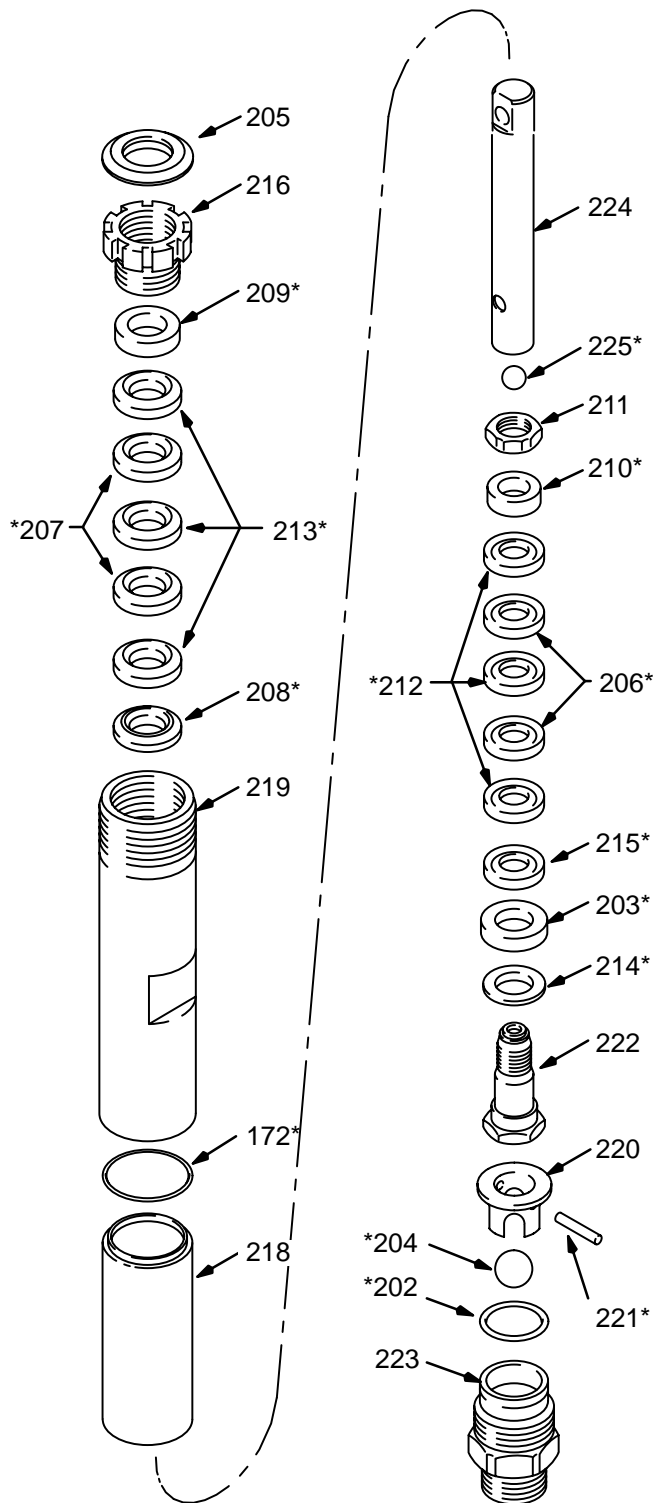
## Model 220-872, Series A

Displacement Pump  
Includes items 202 to 225

Ref. No.	Part No.	Description	Qty.
202*	107-098	PACKING, o-ring, PTFE	1
203*	108-690	SEAL, u-cup, polyurethane	1
204*	108-775	BALL; sst	1
205	183-171	PLUG	1
206*	183-174	V-PACKING, leather	2
207*	183-175	V-PACKING, leather	2
208*	183-176	GLAND, male	1
209*	183-177	GLAND, female	1
210*	183-178	GLAND, male	1
211	183-179	NUT, hex, retaining	1
212*	183-182	V-PACKING, plastic	3
213*	183-183	V-PACKING, plastic	3
214*	183-653	WASHER, backup	1
215*	183-185	GLAND, female	1
216	183-186	NUT, packing	1
217*	183-172	O-RING, PTFE	1
218	183-361	SLEEVE, cylinder	1
219	183-181	CYLINDER	1
220	183-180	GUIDE, ball	1
221*	183-173	PIN, ball stop	1
222	220-631	VALVE, piston	1
223	220-629	VALVE, intake	1
224	220-630	ROD, piston	1
225*	101-947	BALL	1

\* These parts are also included in **Displacement Pump Repair Kit 220-877**, which may be purchased separately.

A **Sleeve Removal Tool, P/N 220-991**, is required for removing a stuck sleeve. Purchase separately.



# Danger Labels

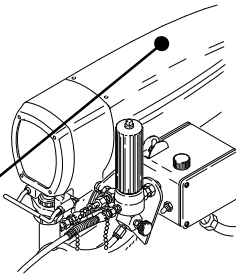
## DANGER LABELS

The English language DANGER label shown on page 1 is also on your sprayer. If you have painters who do not read English, order one of the following labels to apply to your sprayer. The drawing below shows the best placement of these labels for good visibility.

Order the labels directly from Graco, free of charge. Toll Free: **1-800-367-4023**

<b>French</b>	<b>185-956</b>
<b>Spanish</b>	<b>185-961</b>
<b>German</b>	<b>186-041</b>
<b>Greek</b>	<b>186-045</b>
<b>Korean</b>	<b>186-049</b>
<b>English</b>	<b>185-593</b>

Apply other  
language here



# Manual Change Summary

A 120 V Circuit Breaker, P/N 112-152 has been added to the parts list at Ref No. 107. The circuit breaker may be replaced. It is located at the back inside of the Pressure Control (item 43), just below the toggle switch.

# Technical Data

Power Requirements (full output) . . . . 120 VAC, 60Hz,  
1 phase, 18 amp minimum  
Working Pressure Range . . . . 0–3000 psi (0 – 210 bar)  
Cycles/Gallon (liter) . . . . . 104 (27.5)  
Power Cord . . . . . No. 12 AWG, 3 wire, 10' (3 m)  
Inlet Paint Strainer . . . . . 16 mesh (1190 micron)  
Stainless steel screen, reusable  
Outlet Paint Filter . . . . . 60 mesh (250 micron)  
Stainless steel screen, reusable  
Pump Inlet Size . . . . . 3/4 npt(m)  
Fluid Outlet Size . . . . . 1/4 npsm from fluid filter  
Wetted Parts:  
*Displacement Pump* . . . Carbon steel, Polyurethane,  
Polyethylene, Delrin®, Leather  
*Filter* . . . . . Aluminum, Carbon steel, Stainless steel,

**NOTE:** Delrin® is a registered trademark of the DuPont Company.

# Dimensions

Weight (w/o packaging) . . . . . 122 lb (55.5 kg)  
Height . . . . . 32 in. (813 mm)  
Length . . . . . 24.25 in. (616 mm)  
Width . . . . . 22.5 in. (572 mm)

## Graco Phone Numbers

**TO PLACE AN ORDER**, contact your Graco distributor, or call this number to identify the distributor closest to you: **1-800-367-4023 Toll Free**

**FOR TECHNICAL ASSISTANCE**, service repair information or assistance regarding the application of Graco equipment: **1-800-543-0339 Toll Free**

# The Graco Warranty and Disclaimers

## WARRANTY

Graco warrants all equipment manufactured by it and bearing its name to be free from defects in material and workmanship on the date of sale by an authorized Graco distributor to the original purchaser for use. As purchaser's sole remedy for breach of this warranty, Graco will, for a period of twelve months from the date of sale, repair or replace any part of the equipment proven defective, with the exception of defects in parts on the drive train/gear box on EM and GM sprayers or power train on EH and GH sprayers, which will be repaired or replaced for twenty-four months from the date of sale for Gas-Hydraulic (GH) and Gas-Mechanical (GM) sprayers and for thirty-six months from the date of sale for Electric-Mechanical (EM), Electric-Hydraulic (EH), 390st and 490st sprayers. This warranty applies only when the equipment is installed, operated and maintained in accordance with Graco's written recommendations.

This warranty does not cover, and Graco shall not be liable for, any malfunction, damage or wear caused by faulty installation, misapplication, abrasion, corrosion, inadequate or improper maintenance, negligence, accident, tampering, or substitution of non-Graco component parts. Nor shall Graco be liable for malfunction, damage or wear caused by the incompatibility with Graco equipment of structures, accessories, equipment or materials not supplied by Graco, or the improper design, manufacture, installation, operation or maintenance of structures, accessories, equipment or materials not supplied by Graco.

This warranty is conditioned upon the prepaid return of the equipment claimed to be defective to an authorized Graco distributor for verification of the claim. If the claimed defect is verified, Graco will repair or replace free of charge any defective parts. The equipment will be returned to the original purchaser transportation prepaid. If inspection of the equipment does not disclose any defect in material or workmanship, repairs will be made at a reasonable charge, which charges may include the costs of parts, labor and transportation.

## DISCLAIMERS AND LIMITATIONS

The terms of this warranty constitute purchaser's sole and exclusive remedy and are in lieu of any other warranties (express or implied), **including warranty of merchantability or warranty of fitness for a particular purpose**, and of any non-contractual liabilities, including product liabilities, based on negligence or strict liability. Every form of liability for direct, special or consequential damages or loss is expressly excluded and denied. In no case shall Graco's liability exceed the amount of the purchase price. Any action for breach of warranty must be brought within two (2) years of the date of sale.

## EQUIPMENT NOT COVERED BY GRACO WARRANTY

Graco makes no warranty, and disclaims all implied **warranties of merchantability and fitness for a particular purpose**, with respect to accessories, equipment, materials, or components sold but not manufactured by Graco. These items sold, but not manufactured by Graco (such as electric motor, switches, hose, etc.) are subject to the warranty, if any, of their manufacturer. Graco will provide purchaser with reasonable assistance in making any claim for breach of these warranties.

**Sales Offices:** Atlanta, Chicago, Dallas, Detroit, Los Angeles, Mt. Arlington (N.J.)  
**Foreign Offices:** Canada; England; Korea; Switzerland; France; Germany; Hong Kong; Japan

**GRACO INC. P.O. BOX 1441 MINNEAPOLIS, MN 55440-1441**

PRINTED IN U.S.A. 307-726 5/89 Revised 9/93