

Electric Airless Sprayers

312361D

- For portable spray application of architectural paints and coatings -

Maximum Working Pressure: 3300 psi (227 bar, 22.7 MPa)



IMPORTANT SAFETY INSTRUCTIONS

Read all warnings and instructions. Save these instructions. Contact ASM Customer Service or your local ASM distributor to obtain a manual in your language.

Related Manuals



312360



312363 (English)
312364 (Spanish)
312365 (French)



312362

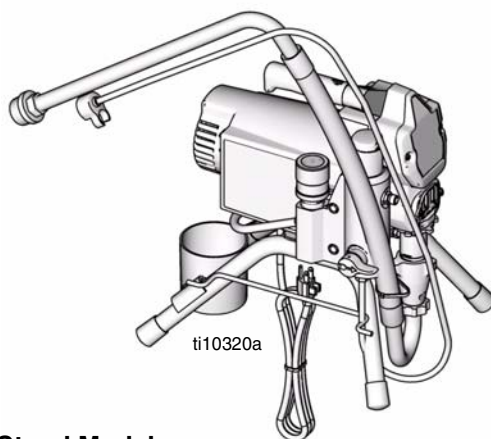

ti10320a

Stand Models:

ASM Zip-Spray™ 2100 Plus 110V: 247482
ASM AllPro Mustang 4700 Plus 110V: 247483
ASM Zip-Spray™ 2100 Plus 240V: 247484

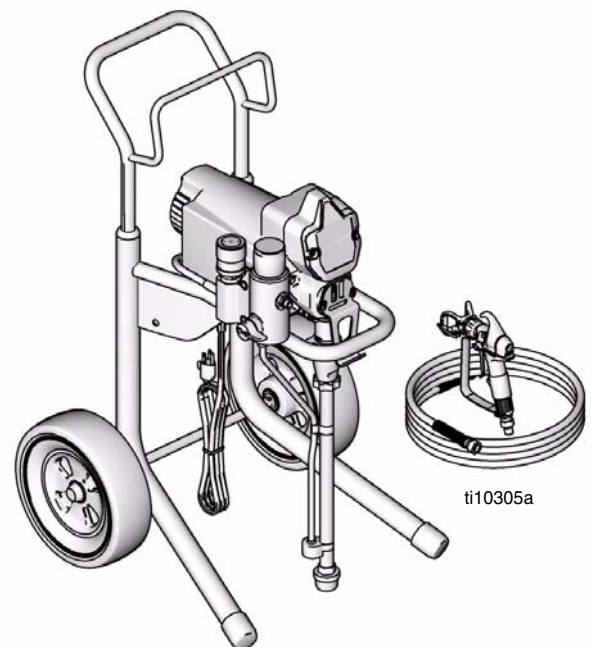





ti10305a







Hi-Boy Models:

ASM Zip-Spray™ 2100 Plus 110V: 247485
ASM AllPro Mustang 4700 Plus 110V: 247486
ASM Zip-Spray™ 2100 Plus 240V: 247487
ASM L1900 Plus 110V: 247494
ASM L1900 Plus 240V: 247495
ASM Zip-Spray™ 2300 Plus 110V: 247531
ASM AllPro Mach 5400 Plus 110V: 247532

Warning

The following warnings are for the setup, use, grounding, maintenance and repair of this equipment. The exclamation point symbol alerts you to a general warning and the hazard symbol refers to procedure-specific risks. Refer back to these warnings. Additional, product-specific warnings may be found throughout the body of this manual where applicable.

 WARNING	
	<p>FIRE AND EXPLOSION HAZARD</p> <p>Flammable fumes, such as solvent and paint fumes, in work area can ignite or explode. To help prevent fire and explosion:</p> <ul style="list-style-type: none"> • Use equipment only in well ventilated area. • Eliminate all ignition sources; such as pilot lights, cigarettes, portable electric lamps, and plastic drop cloths (potential static arc). • Sprayer generates sparks. When flammable liquid is used in or near the sprayer or for flushing or cleaning, keep sprayer at least 20 feet (6 m) away from explosive vapors. • Keep work area free of debris, including solvent, rags and gasoline. • Do not plug or unplug power cords or turn lights on or off when flammable fumes are present. • Ground equipment and conductive objects in work area. Read Grounding instructions. • If there is static sparking or you feel a shock, stop operation immediately. Do not use equipment until you identify and correct the problem. • Keep a working fire extinguisher in the work area.
	<p>ELECTRIC SHOCK HAZARD</p> <p>Improper grounding, setup, or usage of the system can cause electric shock.</p> <ul style="list-style-type: none"> • Turn off and disconnect power cord before servicing equipment. • Use only grounded electrical outlets. • Use only 3-wire extension cords. • Ensure ground prongs are intact on sprayer and extension cords. • Do not expose to rain. Store indoors.
	<p>SKIN INJECTION HAZARD</p> <p>High-pressure fluid from gun, hose leaks, or ruptured components will pierce skin. This may look like just a cut, but it is a serious injury that can result in amputation. Get immediate surgical treatment.</p> <ul style="list-style-type: none"> • Do not point gun at anyone or at any part of the body. • Do not put your hand over the spray tip. • Do not stop or deflect leaks with your hand, body, glove, or rag. • Engage trigger lock when not spraying. • Follow Pressure Relief Procedure in this manual, when you stop spraying and before cleaning, checking, or servicing equipment.

	WARNING
	<p>EQUIPMENT MISUSE HAZARD</p> <p>Misuse can cause death or serious injury.</p> <ul style="list-style-type: none"> • Do not exceed the maximum working pressure or temperature rating of the lowest rated system component. Read Technical Data in all equipment manuals. • Use fluids and solvents that are compatible with equipment wetted parts. Read Technical Data in all equipment manuals. Read fluid and solvent manufacturer's warnings. For complete information about your material, request MSDS from distributor or retailer. • Check equipment daily. Repair or replace worn or damaged parts immediately with genuine ASM replacement parts only. • Do not alter or modify equipment. • Use equipment only for its intended purpose. Call your ASM distributor for information. • Route hoses and cables away from traffic areas, sharp edges, moving parts, and hot surfaces. • Do not kink or overbend hoses or use hoses to pull equipment. • Keep children and animals away from work area. • Comply with all applicable safety regulations. • Keep children and animals away from work area. • Do not operate the unity when fatigued or under the influence of drugs or alcohol.
	<p>PRESSURIZED ALUMINUM PARTS HAZARD</p> <p>Do not use 1,1,1-trichloroethane, methylene chloride, other halogenated hydrocarbon solvents or fluids containing such solvents in pressurized aluminum equipment. Such use can cause serious chemical reaction and equipment rupture, and result in death, serious injury, and property damage.</p>
	<p>BURN HAZARD</p> <p>Equipment surfaces can become very hot during operation. To avoid severe burns, do not touch hot equipment. Wait until equipment has cooled completely.</p>
	<p>MOVING PARTS HAZARD</p> <p>Moving parts can pinch or amputate fingers and other body parts.</p> <ul style="list-style-type: none"> • Keep clear of moving parts. • Do not operate equipment with protective guards or covers removed. • Pressurized equipment can start without warning. Before checking, moving, or servicing equipment, follow the Pressure Relief Procedure in this manual. Disconnect power or air supply.
	<p>TOXIC FLUID OR FUMES HAZARD</p> <p>Toxic fluids or fumes can cause serious injury or death if splashed in the eyes or on skin, inhaled, or swallowed.</p> <ul style="list-style-type: none"> • Read MSDS's to know the specific hazards of the fluids you are using. • Store hazardous fluid in approved containers, and dispose of it according to applicable guidelines.
	<p>PERSONAL PROTECTIVE EQUIPMENT</p> <p>You must wear appropriate protective equipment when operating, servicing, or when in the operating area of the equipment to help protect you from serious injury, including eye injury, inhalation of toxic fumes, burns, and hearing loss. This equipment includes but is not limited to:</p> <ul style="list-style-type: none"> • Protective eye wear • Clothing and respirator as recommended by the fluid and solvent manufacturer • Gloves • Hearing protection

Component Identification (Stand)

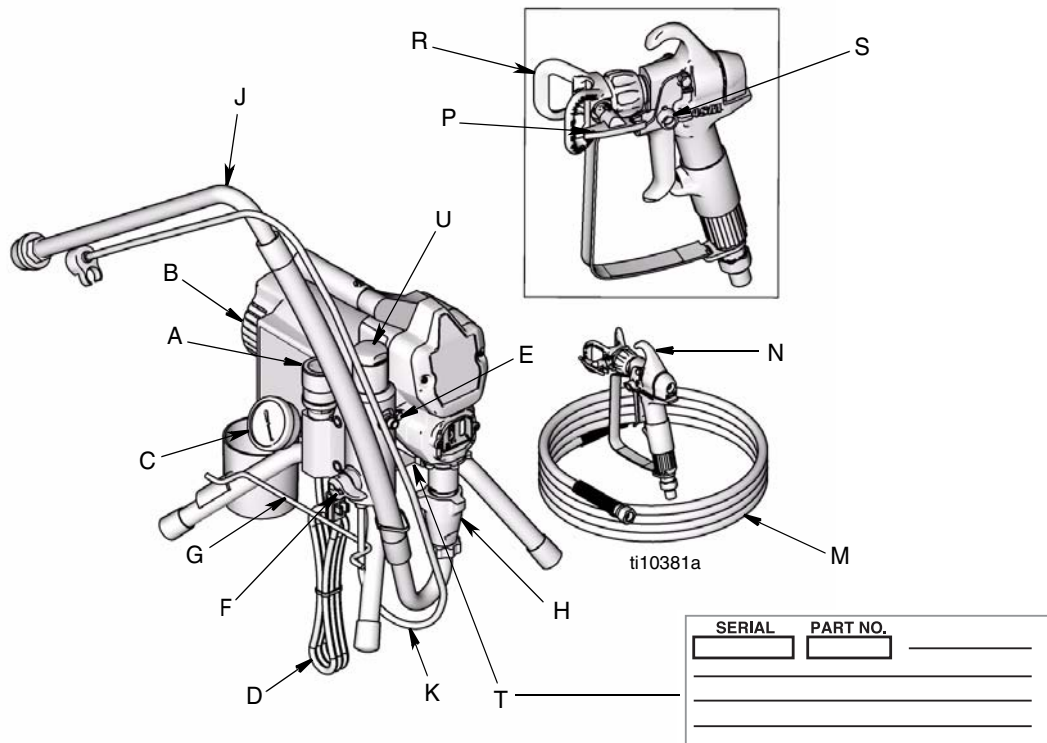

Item	Component
A	Pressure Control
B	ON/OFF switch
C	Pressure Gauge (not on all models)
D	Power Cord
E	Fluid Outlet
F	Prime Valve
G	Cord Wrap
H	Pump
J	Suction Hose
K	Drain Hose
M	Fluid Hose
N	Gun
P	Tip
R	Guard
S	Trigger Safety Lock
T	Serial Number ID Label
U	Filter Cover

Component Identification (Hi-Boy)

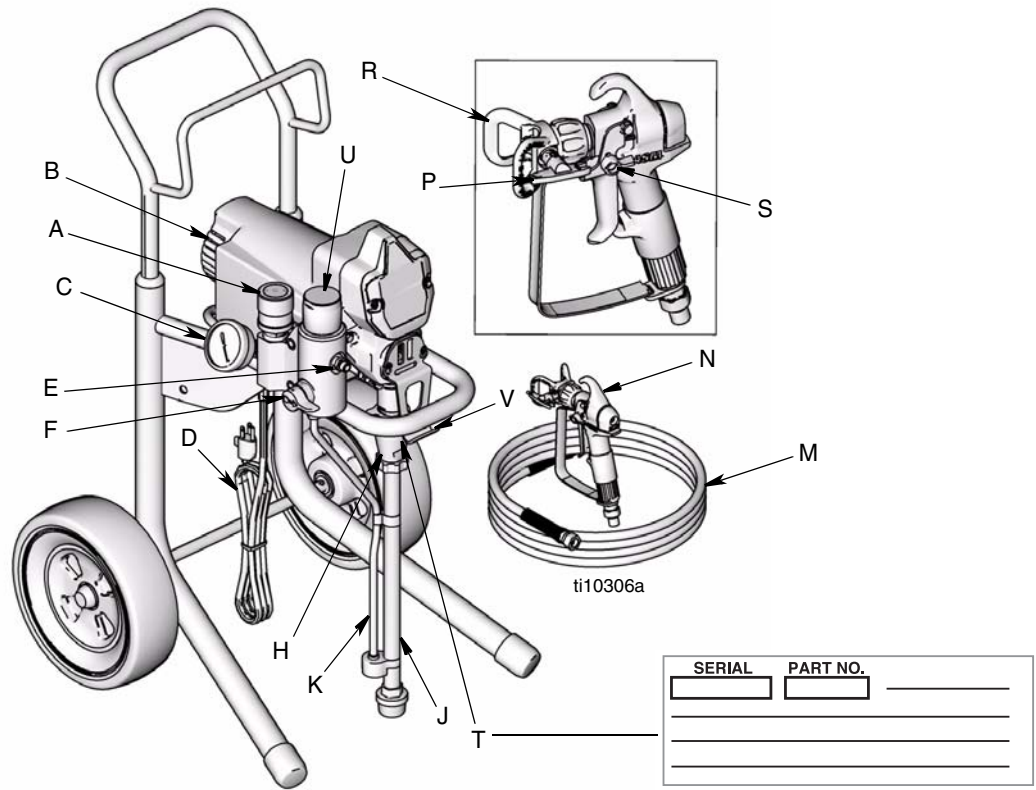

Item	Component
A	Pressure Control
B	ON/OFF switch
C	Pressure Gauge (not on all models)
D	Power Cord
E	Fluid Outlet
F	Prime Valve
H	Pump
J	Suction Hose
K	Drain Hose
M	Fluid Hose
N	Gun
P	Tip
R	Guard
S	Trigger Safety Lock
T	Serial Number ID Label
U	Filter Cover
V	Pail Hook

Installation

Grounding and Electric Requirements



The sprayer cord includes a grounding wire with an appropriate grounding contact.

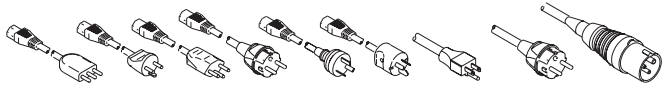

The sprayer requires:

110-120V Units: 100-130VAC, 50/60 Hz, 11A, 1 phase, circuit with a grounding receptacle.

240V Units: 210-255 VAC, 50/60 Hz, 7.5A, 1 phase, circuit with a grounding receptacle.

Never use an outlet that is not grounded or an adapter.

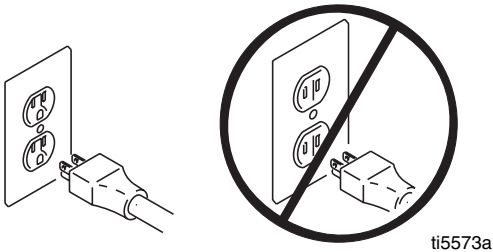

ti5573a

Do not use the sprayer if the electrical cord has a damaged ground contact. Only use an extension cord with an undamaged ground contact.

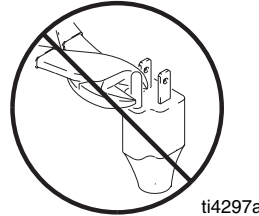

ti4297a

Recommended extension cords for use with this sprayer:

- 110-120V: 3-wire, 12 AWG (2.5 mm²) minimum, 300 ft. (90 m) maximum length.
- 240V: 3-wire, 16 AWG (1.0 mm²) minimum, 300 ft (90 m) maximum length.

 Smaller gauge or longer extension cords may reduce sprayer performance.

Spray gun: ground through connection to a properly grounded fluid hose and pump.

Fluid supply container: follow local code.

Solvent and Oil-based fluids: follow local code. Use only conductive metal pails placed on a grounded surface such as concrete. Do not place the pail on a non-conductive surface such as paper or cardboard, which interrupts grounding continuity.

Grounding the metal pail: connect a ground wire to the pail by clamping one end to pail and other end to ground such as a water pipe.

To maintain grounding continuity when flushing or relieving pressure: hold metal part of the spray gun firmly to the side of a grounded metal pail, then trigger the gun.



ti10344a

Pressure Relief Procedure



Follow this **Pressure Relief Procedure** whenever you are instructed to relieve pressure, stop spraying, check or service equipment or install or clean spray tip.

1. Turn OFF power and turn pressure control to lowest pressure setting.
2. Hold gun against side of grounded metal flushing pail. Trigger gun to relieve pressure.



3. Turn prime valve down.

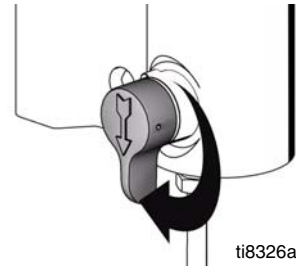

If you suspect the spray tip or hose is clogged or that pressure has not been fully relieved after following the steps above, VERY SLOWLY loosen tip guard retaining nut or hose end coupling to relieve pressure gradually, then loosen completely. Clear hose or tip obstruction.

4. Engage trigger safety lock on gun if unit is being shut down or left unattended.

General Repair Information

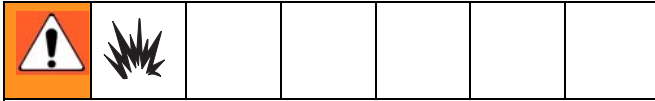
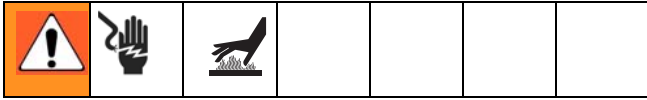

Flammable materials spilled on hot, bare, motor could cause fire or explosion. To reduce risk of burns, fire or explosion, do not operate sprayer with cover removed.

- Keep all screws, nuts, washers, gaskets, and electrical fittings removed during repair procedures. These parts usually are not provided with replacement kits.
- Test repairs after problems are corrected.
- If sprayer does not operate properly, review repair procedure to verify you did it correctly. See **Troubleshooting**, page 9.
- Overspray may build up in the air passages. Remove any overspray and residue from air passages and openings in the enclosures whenever you service sprayer.
- Do not operate the sprayer without the motor shroud in place. Replace if damaged. Motor shroud directs cooling air around motor to prevent overheating and insulate the control board from accidental electric shock.



To reduce risk of serious injury, including electric shock:

- Do not touch moving or electric parts with fingers or tools while testing repair.
- Unplug sprayer when power is not required for testing.
- Install all covers, gaskets, screws and washers before you operate sprayer.

CAUTION

- Do not run sprayer dry for more than 30 seconds. Doing so could damage pump packings.
- Protect the internal drive parts of this sprayer from water. Openings in the cover allow for air cooling of the mechanical parts and electronics inside. If water gets in these openings, the sprayer could malfunction or be permanently damaged.
- Prevent pump corrosion and damage from freezing. Never leave water or water-base paint in sprayer when its not in use in cold weather. Freezing fluids can seriously damage sprayer. Store sprayer with Pump Armor to protect sprayer during storage.

Troubleshooting



Problem	What To Check <i>(If check is OK, go to next check)</i>	What To Do <i>(When check is not OK, refer to this column)</i>
Motor Won't Operate		
Basic Fluid Pressure	1. Pressure control knob setting. Motor will not run if set at minimum (fully counter-clockwise).	Slowly increase pressure setting to see if motor starts.
	2. Spray tip or fluid filter may be clogged.	Relieve pressure , page 7. Then clear clog or clean gun filter. Refer to gun instruction manual, 312363.
Basic Mechanical	1. Pump frozen or hardened paint	Thaw sprayer if water or water-based paint has frozen in sprayer. Place sprayer in warm area to thaw. Do not start sprayer until thawed completely. If paint hardened (dried) in sprayer, replace pump packings. See page 13, Displacement Pump Replacement .
	2. Displacement pump connecting rod pin. Pin must be completely pushed into connecting rod and retaining spring must be firmly in groove or pump pin.	Push pin into place and secure with spring retainer. See page 13, Displacement Pump Replacement .
	3. Motor. Remove drive housing assembly. See page 15, Drive Housing Replacement . Try to rotate fan by hand.	Replace motor if fan won't turn. See page 26, Motor Replacement .

Problem	What To Check <i>(If check is OK, go to next check)</i>	What To Do <i>(When check is not OK, refer to this column)</i>
Basic Electrical (see Wiring Diagram , page 27).	1. Electric supply. Meter must read 100-130 VAC for 110-120 VAC models and 210-255 VAC for 240 VAC models.	Reset building circuit breaker, replace building fuses. Try another outlet.
	2. Extension cord. Check extension cord continuity with volt meter.	Replace extension cord.
	3. Sprayer power supply cord. Inspect for damage such as broken insulation or wires.	Replace power supply cord. See page 25, Power Cord Replacement .
	4. Fuse. Check replaceable fuse on control board (next to ON/OFF switch).	Replace fuse after completing motor inspection. See page 21, Fuse Replacement .
	5. Motor leads are securely fastened and properly connected to control board.	Replace loose terminals; crimp to leads. Be sure terminals are firmly connected. Clean circuit board terminals. Securely reconnect leads.
	6. Motor thermal switch. Yellow motor leads must have continuity through thermal switch.	Replace motor. See page 18, Motor Replacement .
	7. Brush cap missing or loose brush lead connections.	Install brush cap or replace brushes if leads are damaged. See page 18, Motor Brush Replacement .
	8. Brush length which must be 1/4 in. (6mm) minimum. NOTE: Brushes do not wear at the same rate on both sides of motor. Check both brushes.	Replace brushes. See page 18, Motor Brush Replacement .
	9. Motor armature commutator for burn spots, gouges and extreme roughness.	Remove motor and have motor shop resurface commutator if possible. See page 18, Motor Replacement .
	10. Motor armature for shorts using armature tester (growler) or perform spin test, page 16.	Replace motor. See page 18, Motor Replacement .
	11. Pressure control not plugged in to control board.	Insert pressure control connector into control board.

Problem	What To Check <i>(If check is OK, go to next check)</i>	What To Do <i>(When check is not OK, refer to this column)</i>
Low Output	1. Worn spray tip.	Relieve pressure , page 7. Replace tip. Refer to gun instruction manual, 312363.
	2. Verify pump does not continue to stroke when gun trigger is released.	Service pump. See page 13, Displacement Pump Replacement .
	3. Prime valve leaking.	Relieve pressure , page 7. Then repair prime valve. See page 23, Drain Valve Replacement .
	4. Suction hose connections.	Tighten any loose connections. Check o-rings on suction hose swivel.
	5. Electric supply with volt meter. Meter must read 100-130 VAC for 110-120 VAC models and 210-255 for 240 VAC models. Low voltages reduce sprayer performance.	Reset building circuit breaker; replace building fuse. Repair electrical outlet or try another outlet.
	6. Extension cord size and length.	Replace with a correct, grounded extension cord. See page 6, Grounding and Electric Requirements .
	7. Leads from motor to circuit board for damaged or loose wire connectors. Inspect wiring insulation and terminals for signs of overheating.	Be sure male terminal pins are centered and firmly connected to female terminals. Replace any loose terminals or damaged wiring. Securely reconnect terminals.
	8. Worn motor brushes which must be 1/4 in. (6 mm) minimum.	Replace brushes. See page 18. Motor Brush Replacement .
	9. Motor brushes binding in brush holders.	Clean brush holders. Remove carbon dust by using compressed air to blow out brush dust.
	10. Low stall pressure. Turn pressure control knob fully clockwise.	Replace pressure control assembly. See page 22, Pressure Control Assembly Replacement .
	11. Motor armature for shorts by using an armature tester (growler) or perform spin test, page 16.	Replace motor. See page 26, Motor Replacement .

<p>Problem</p>	<p>What To Check <i>(If check is OK, go to next check)</i></p>	<p>What To Do <i>(When check is not OK, refer to this column)</i></p>
<p>Motor runs and pump strokes</p>	<p>1. Prime Valve Open.</p>	<p>Close prime valve.</p>
	<p>2. Paint supply.</p>	<p>Refill and reprime pump.</p>
	<p>3. Intake strainer clogged.</p>	<p>Remove and clean, then reinstall.</p>
	<p>4. Suction hose leaking air.</p>	<p>Tighten nut. Check o-rings on swivel.</p>
	<p>5. Intake valve ball and piston ball are seating properly.</p>	<p>See Pump Manual 312362. Strain paint before using to remove particles that could clog pump.</p>
	<p>6. Leaking around throat packing nut which may indicate worn or damaged packings.</p>	<p>See Pump Manual 312362.</p>
	<p>7. Pump rod damaged.</p>	<p>See Pump Manual 312362.</p>
<p>Motor runs but pump does not stroke</p>	<p>1. Displacement pump pin damaged or missing.</p>	<p>Replace pump pin if missing. Be sure retaining spring is fully in groove all around connecting rod. See page 13, Displacement Pump Replacement.</p>
	<p>2. Connecting rod assembly for damage.</p>	<p>Replace connecting rod assembly. See page 13, Displacement Pump Replacement.</p>
	<p>3. Gears or drive housing.</p>	<p>Inspect drive housing assembly and gears for damage and replace if necessary. See page 15, Drive Housing Replacement.</p>
<p>Motor is hot and runs intermittently</p>	<p>1. Be sure ambient temperature where sprayer is located is not more than 115°F (46°C) and sprayer is not located in direct sun.</p>	<p>Move sprayer to shaded, cooler area if possible.</p>
	<p>2. Motor has burned windings indicated by removing positive (red) brush and seeing burned adjacent commutator bars.</p>	<p>Replace motor. See page 26, Motor Replacement.</p>
	<p>3. Tightness of pump packing nut. Overtightening tightens packings on rod, restricts pump action and damages packings.</p>	<p>Loosen packing nut. Check for leaking around throat. Replace pump packings if necessary. See pump manual 312362.</p>

Displacement Pump Replacement

See manual 312362 for pump repair instructions.

Removal

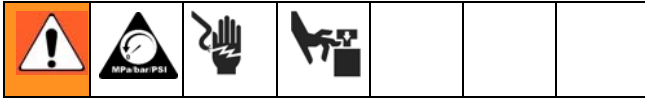

1. **Relieve Pressure**, page 7. Unplug sprayer from outlet.
2. **Stand Models** - Loosen two screws (11) and rotate cover (10).
Hi-Boy Models - Loosen two screws (11) and remove pail hook (10).

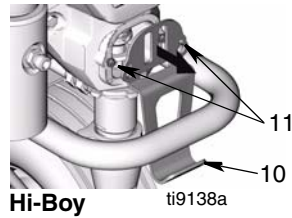
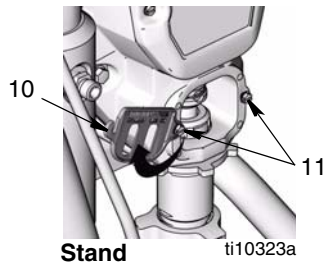

3. Loosen nut (A) and remove suction hose (B).
4. Loosen nut (C) and remove the high pressure hose (D).

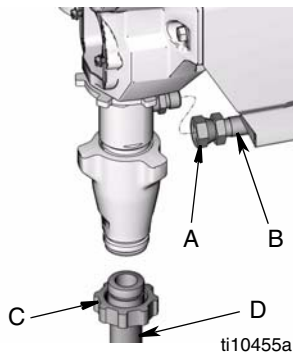

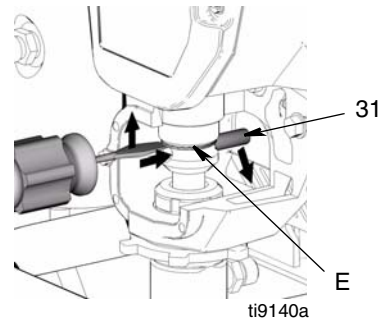

5. Cycle pump until pin (31) is in position to be removed.
6. Disconnect power cord from outlet.
7. Use flat screwdriver push to push retaining spring (E) up. Push out pump pin (31).

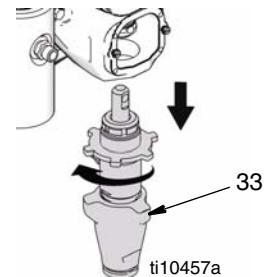
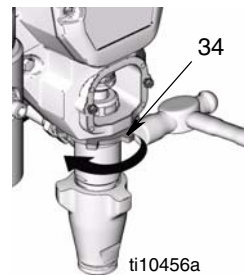

8. Use hammer to loosen pump jam nut (34). Unscrew and remove pump (33).



Installation

						
<p>If pump pin works loose, parts could break off due to force of pumping action. Parts could project through air and result in serious injury or property damage.</p>						

CAUTION
<p>If the pump jam nut loosens during operation, the threads of the drive housing will be damaged.</p>

1. Extend pump piston rod full. Apply grease to top of pump rod at (F) or inside connecting rod (30). Install jam nut (34) on pump threads.

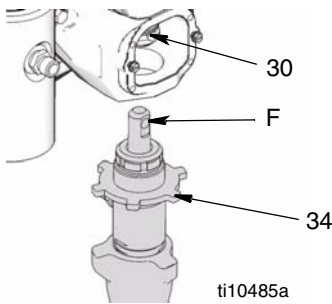

2. Install pump rod (F) into connecting rod (30).
3. Install pump pin (31). Verify retainer spring (E) is in groove over pump pin.

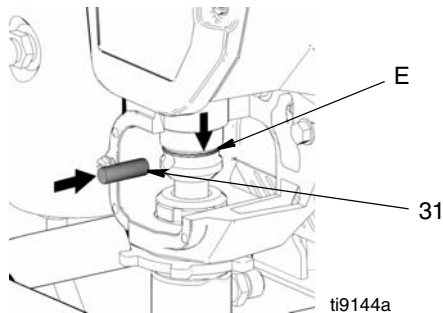

4. Push pump (33) up until pump threads engage.
5. Screw in pump until threads are flush with top of drive housing opening.

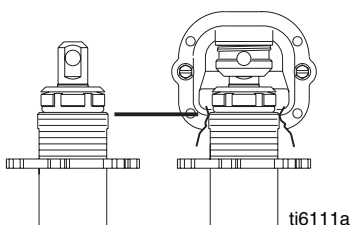

6. Align pump outlet (G) to back.

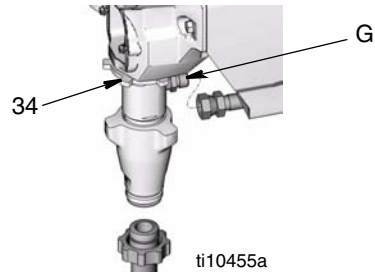

7. Screw jam nut (34) up onto pump until nut stops. Tighten jam nut by hand, then tap 1/8 to 1/4 turn with a 20 oz (maximum) hammer to approximately 75 ft-lb (102 N•m) torque.
8. Install high pressure hose (D) and tighten nut (C) to approximately 35 ft-lb (47 N•m) torque. Install suction tube (B) and hand-tighten nut (A).

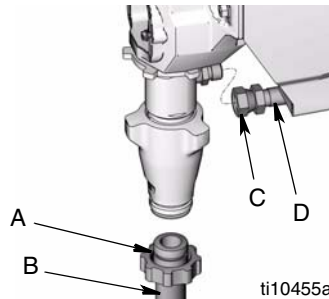

9. Fill packing nut with ASM Packing Seal[®] until fluid flows onto top of seal.

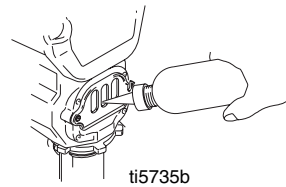

10. **Stand Models** - Rotate cover (10) and tighten screws (11).
Hi-Boy Models - Install pail hook (10) with screws (11).

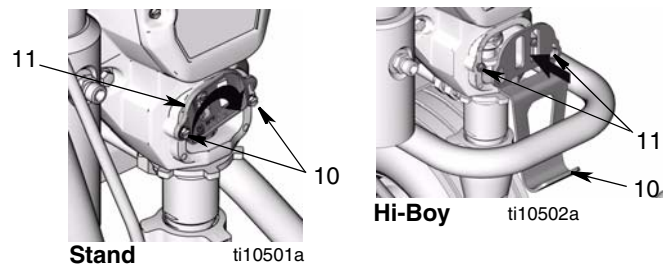

Drive Housing Replacement

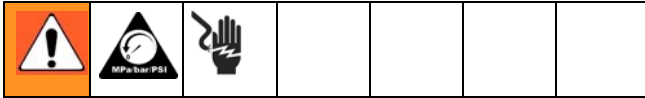

Removal

1. **Relieve Pressure**, page 7.
2. Remove pump (33). **Displacement Pump Replacement**, page 13.
3. Disconnect power cord from outlet.

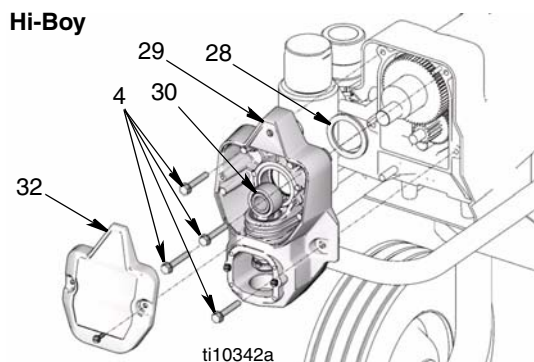
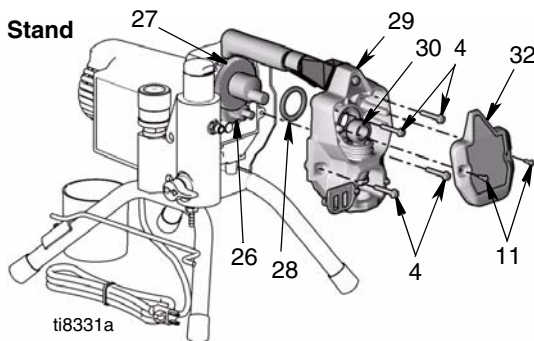

4. Remove two screws (11) and cover (32).
5. **Stand Models** - Remove five screws (4).
Hi-Boy Models - Remove five screws (4).
6. Pull drive housing (29) out of motor front endbell.
7. Remove gear cluster (26) and (27) and thrust bearing (28) from drive housing.

CAUTION

Do not drop gear cluster (26) and (27) when removing drive housing (29). Gear cluster may stay engaged in motor front endbell or drive housing.

Installation

1. Apply a liberal coat of grease to gears and needle bearing surfaces. Install thrust bearing (28) and gears (26) and (27) in front endbell housing.

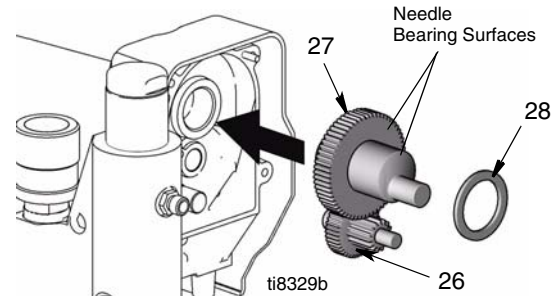

2. Push drive housing into front endbell housing. Insert gear crank (27) through hole in connecting rod (30).

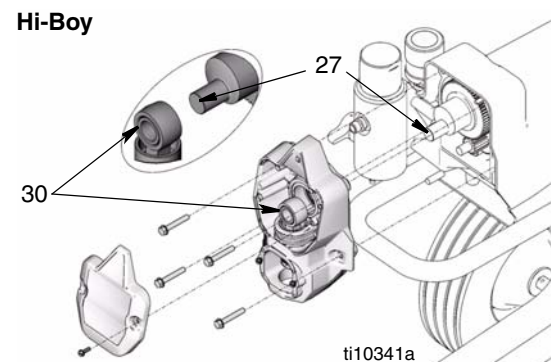
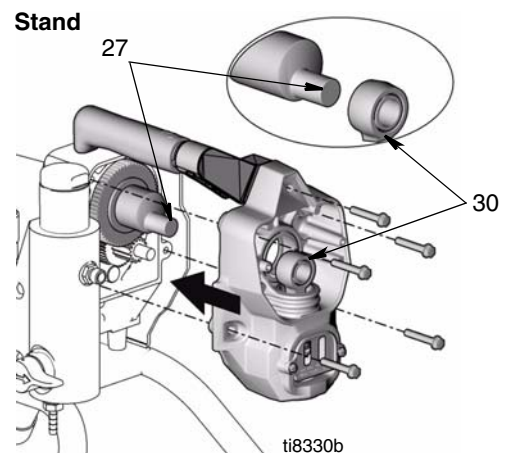

3. **Stand Models** - Install five screws (4).
Hi-Boy Models - Install five screws (4).
4. Install cover (32) with two screws (11).
5. Install pump (33). **Displacement Pump Replacement**, page 13.

Spin Test

See **Wiring Diagram**, page 27.

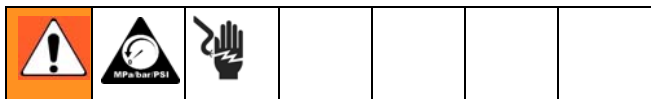

To check armature, motor winding and brush electrical continuity:

1. **Relieve Pressure**, page 7. Disconnect power cord from outlet.
2. **Hi-Boy Models Only** - Disconnect high-pressure hose at pump outlet (see page 13).
3. Remove two screws (4) and shroud (12).
4. Remove drive housing (29) (see page 15).
5. Disconnect motor connector (H).

Armature Short Circuit Test

Quickly turn motor fan by hand. If motor coasts two or three revolutions before complete stop, there are no electrical shorts. If motor does not spin freely, armature is shorted. Replace motor, page 26.

Armature, Brushes, and Motor Wiring Open Circuit Test (Continuity)

1. Connect red and black motor leads with test lead. Turn motor fan by hand at about two revolutions per second.

2. If uneven or no resistance, check for missing brush caps, broken brush springs, brush leads, and worn brushes. Repair as needed, page 18.
3. If still uneven or no resistance, replace motor, page 26.

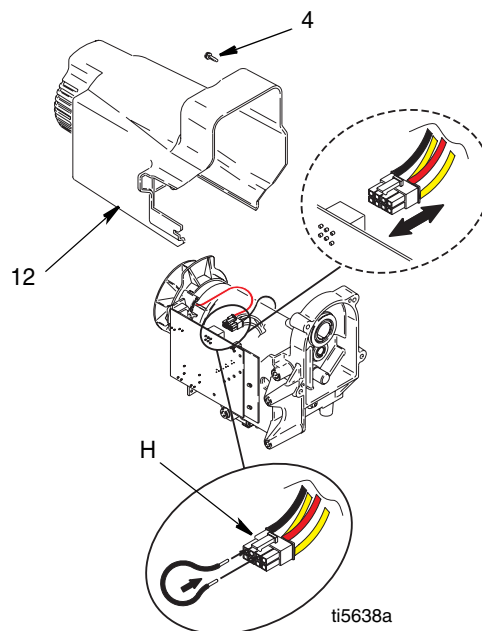

4. Reattach motor connector (H).
5. Replace drive housing (see page 15).
6. Replace shroud (12) and two screws (4).
7. **Hi-Boy Models Only** - Reconnect high-pressure hose at pump outlet (see page 14).

Fan Replacement

Removal

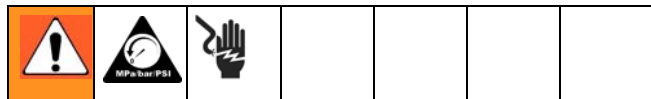

1. **Relieve Pressure**, page 7. Disconnect power cord from outlet.
2. **Hi-Boy Models Only** - Disconnect high-pressure hose at pump outlet (see page 13).
3. Remove two screws (4) and shroud (12).
4. Remove spring clip (57b) on back of motor.
5. Pull off fan (57a).

Installation

1. Slide new fan (57a) in place on back of motor. Be sure blades of fan face motor as shown.
2. Install spring clip (57b).
3. Replace shroud (12) and two screws (4).
4. **Hi-Boy Models Only** - Reconnect high-pressure hose at pump outlet (see page 14).

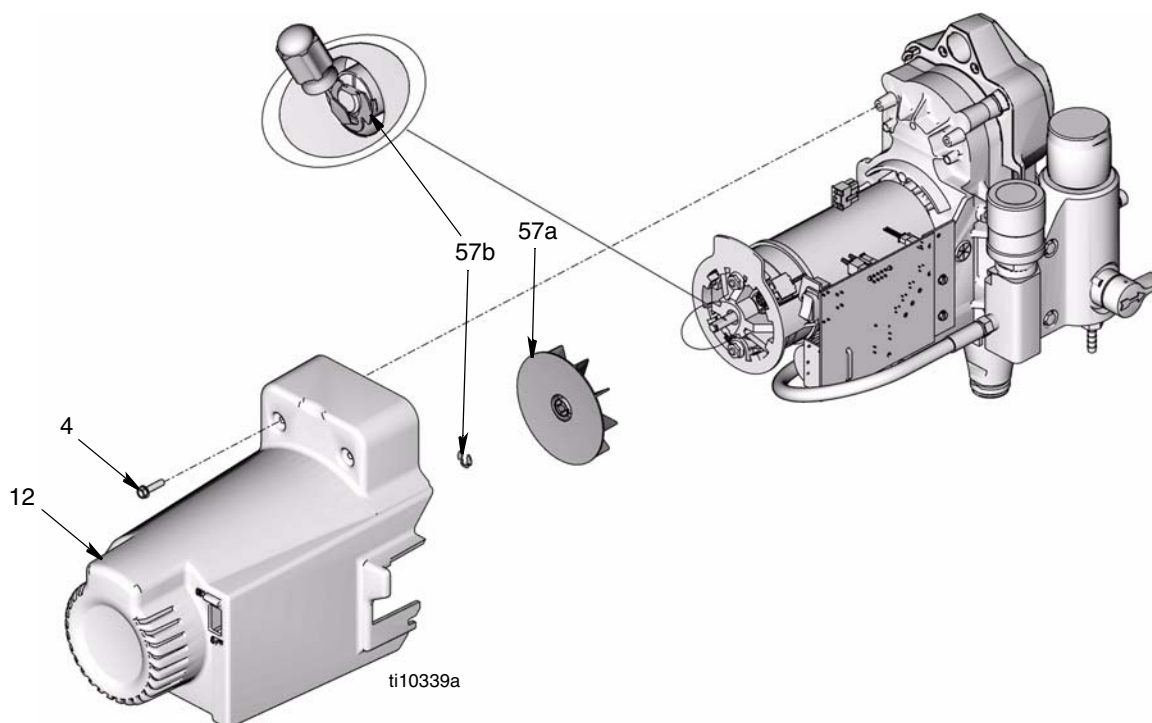

Motor Brush Replacement

See **Wiring Diagram**, page 27.

Removal

Replace brushes worn to less than 1/4 in. (6mm). Brushes wear differently on each side of motor, check both sides.

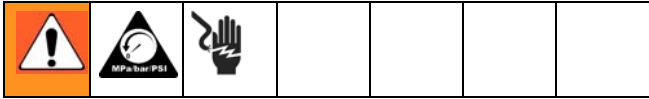

1. **Relieve Pressure**, page 7. Disconnect power cord from outlet.
2. **Hi-Boy Models Only** - Disconnect high-pressure hose at pump outlet (see page 13).
3. Remove two screws (4) and shroud (12) (see illustration on page 17).
4. Disconnect motor connector (D) from control board (18).
5. Cut tie wrap (F).
6. Locate two yellow wires (C) (thermal leads). Cut each yellow wire at the center.
7. Using a flat screwdriver, carefully pry off (two) brush caps (A). Remove brushes (B) from motor.
8. Discard old brush harness.
9. While rotating fan by hand, using compressed air, blow air into positive (top) brush holder to remove brush dust.

 To contain the dust, turn on your shop vac. Place the end of a vacuum over the negative (lower) brush holder while blowing compressed air into the positive (top) brush holder.

Installation

 Use all new parts included in your brush kit. Do not reuse old parts if new replacement parts are provided.

1. With wires facing toward front of motor, install new brushes (B) in motor. Be sure to install the positive (red) brush lead in the top of the motor (as shown)

and the negative (black) brush lead in the side of the motor.

2. Push each cap (A) into place over brush. Orient each cap with the 2 projections on either side of the brush lead. You will hear a “snap” when cap is securely in place.
3. Using a wire stripper, strip off wire insulation approximately 1/4 inch (6 mm) from the end of each yellow wire (C) to the motor.
4. Insert stripped end into end of a butt splice (E) on new brush assembly.
5. Use a crimping tool to squeeze the ends of the butt splice (E) tightly around each wire. Pull gently on each wire to be sure it will not pull out of the butt splice.
6. Reconnect motor connector (D) to control board (18).

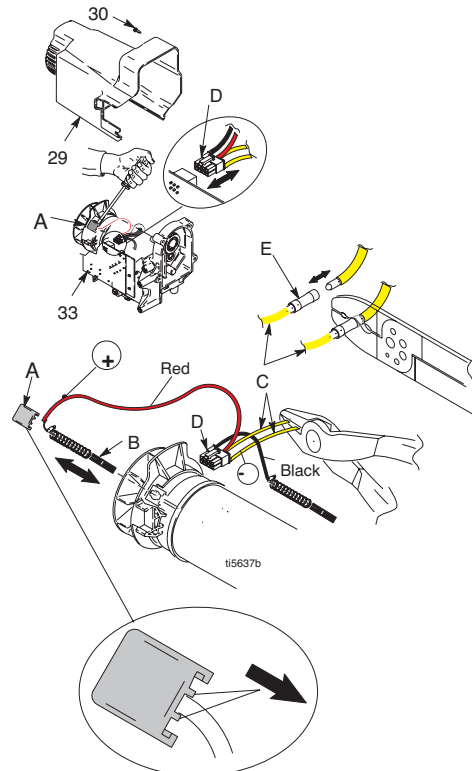

7. Replace shroud (12) and two screws (4) (see illustration, page 17).
8. **Hi-Boy Model Only** - Reconnect high-pressure hose at pump outlet (see page 14).

Control Board Replacement

See **Wiring Diagram**, page 27.



Removal

1. **Relieve Pressure**, page 7. Disconnect power cord from outlet.
2. **Hi-Boy Models Only** - Disconnect high-pressure hose at pump outlet (see page 13).
3. Remove two screws (4) and shroud (12).
4. Disconnect pressure control assembly connector (A) from control board (18) (see page 15).

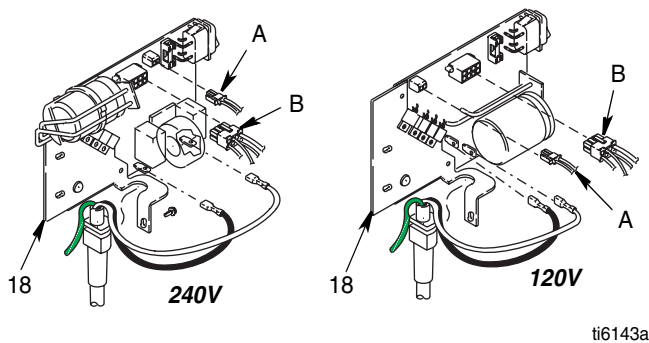

5. Disconnect motor connector (B) from control board (18).
6. Remove three screws (11) securing control board to housing (two are located on the front and one on the back next to the power cord).

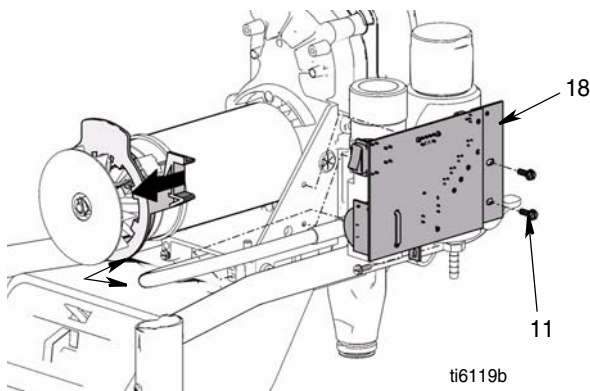

7. Pull control board out slightly and then slide it back and off of frame.

Make sure power cord is free and NOT wrapped around cord wrap.

8. Remove grommet and wires from strain relief.

Ground wire remains attached to sprayer with grounding screw.

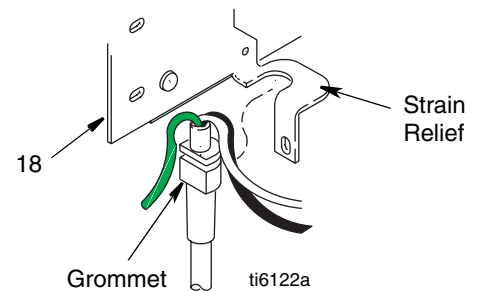

9. Remove two power cord (C) connectors from control board.

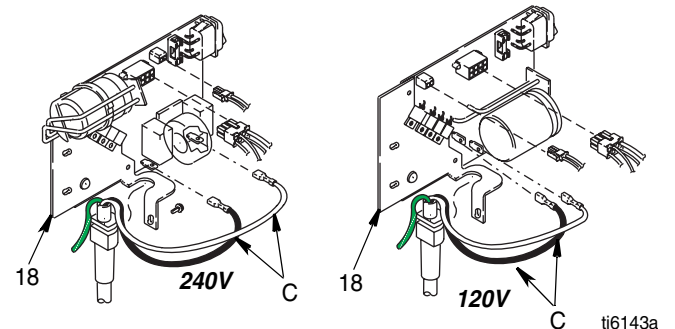

Installation

- 1. Push grommet and power cord wires into strain relief in control board (18).

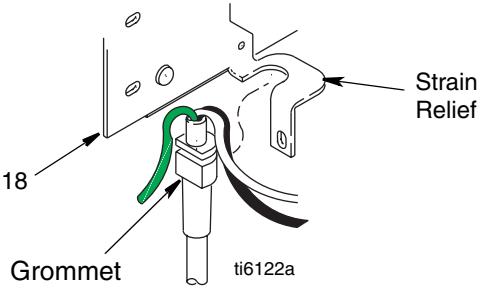

- 2. Connect power cord connectors to terminals indicated on control board (18).

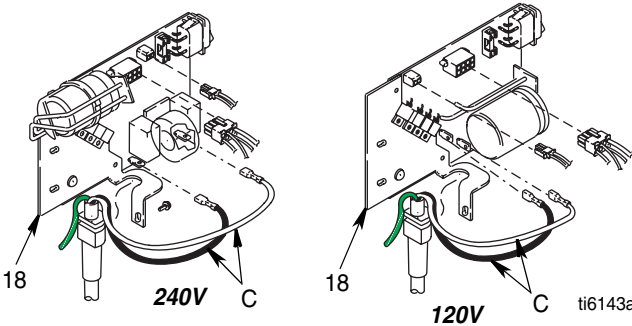

Route power cord (19) between coupled hose (42) to filter manifold and sprayer frame.

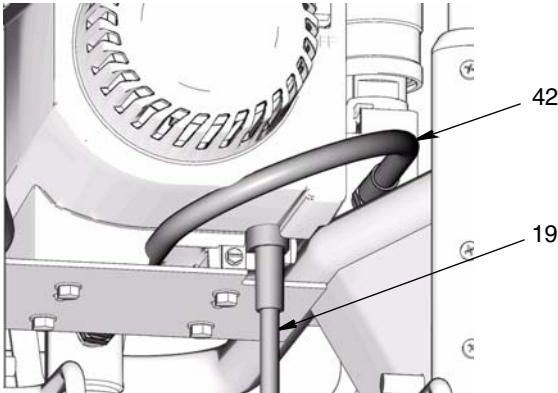

Bottom View of Sprayer ti8322a

- 3. Slide control board into place on side of motor front endbell.

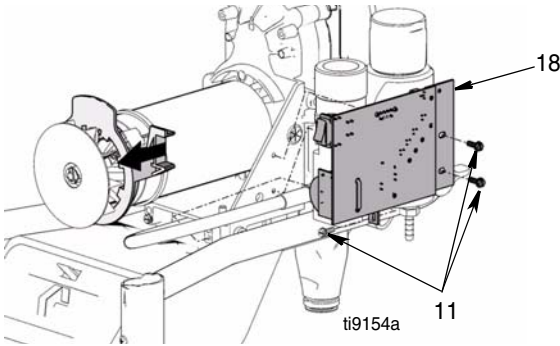

- 4. Replace three screws (11). Torque to 30 - 35 in-lbs (3.4 - 3.9 N•m).

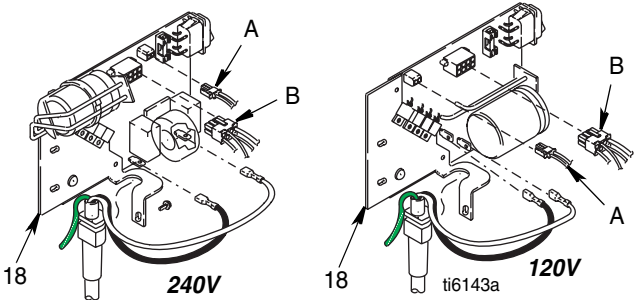

- 5. Connect motor connector (B) and pressure control assembly connector (A).
- 6. Install shroud (12) with screw (4). Install front cover (32) with two screws (11) (see page 15).
- 7. **Hi-Boy Model Only** - Reconnect high-pressure hose at pump outlet (see page 14).

Fuse Replacement

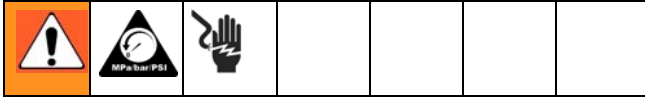

Removal

1. **Relieve pressure**, page 7. Disconnect power cord from outlet.
2. **Hi-Boy Model Only** - Disconnect high-pressure hose at pump (see page 13).
3. Remove two screws (4) and shroud (12) (see illustration, page 17).
4. Remove fuse from control board (18).

Installation

1. Install new fuse on control board (18).
2. Install shroud (12) and two screws (4) (see illustration, page 17).
3. **Hi-Boy Models Only** - Reconnect high pressure hose at pump outlet (see page 14).

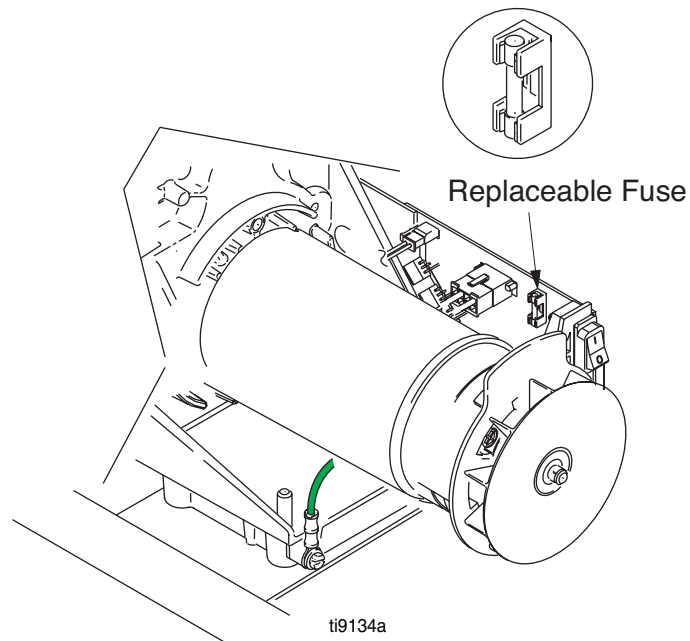

Pressure Control Assembly Replacement

See **Wiring Diagram**, page 27.

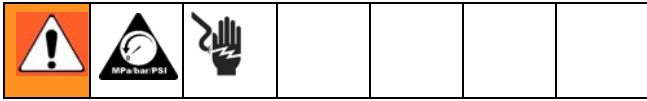

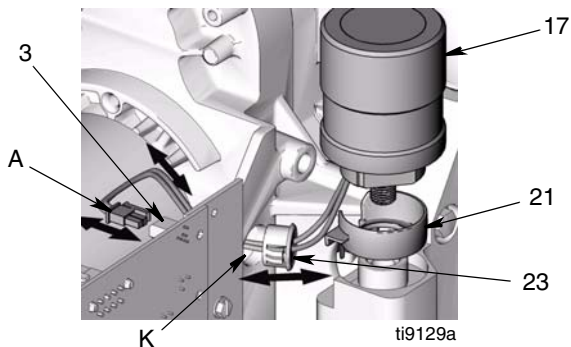

Removal

1. **Relieve pressure**, page 7. Disconnect power cord from outlet.
2. **Hi-Boy Models Only** - Disconnect high-pressure hose at pump outlet (see page 13).
3. Remove two screws (4) and shroud (12) (see illustration, page 17).
4. Disconnect pressure switch connector (A) from control board (18).
5. Remove tape (3) holding wires to manifold.
6. Pull wires back through hole (K) in housing.

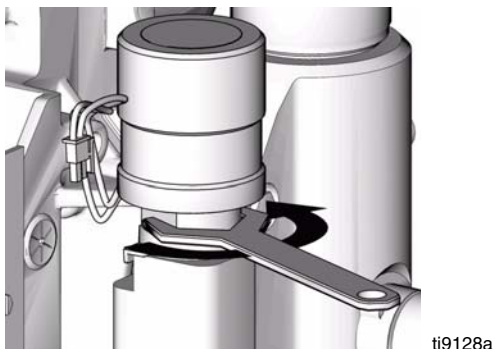

7. Turn the pressure control knob (17) counter clockwise as far as you can to access the flats on either side of the pressure control assembly.
8. Using a 1 in. (26 mm) wrench loosen and unscrew pressure control assembly.



 If you plan to reuse the pressure control assembly, be very careful not to damage or tangle the wires while unscrewing the assembly.

9. Remove pressure control assembly.

Installation

 Inspect pressure control assembly before installation to verify the o-ring is installed and in place.

1. Align pressure control cap (21) on fluid manifold so opening faces toward motor.
2. Apply Loctite® to threads on pressure control assembly (17)
3. Screw pressure control assembly (17) into manifold and torque to 150 in-lbs (17.0 N•m).

 Be careful when tightening pressure control knob that wires do not get pinched between the pressure control assembly and fluid manifold.

4. Route wires around knob and feed through slot in bushing (23).
5. Insert bushing (23) in hole (K) in housing. Secure wires to manifold housing with tape (3).
6. Reconnect pressure switch connector (A) to control board (18).
7. Install shroud (12) and two screws (4) (see illustration, page 17).
8. **Hi-Boy Models Only** - Reconnect high-pressure hose at pump outlet (see page 14).

Drain Valve Replacement

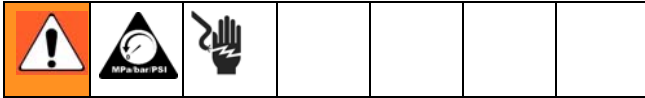

Removal

1. **Relieve pressure**, page 7. Disconnect power cord from outlet.
2. Using a punch and hammer, tap pin (47) out of drain handle (46).
3. Pull drain handle (46) and base (45) off drain valve (44).
4. Using a wrench, loosen drain valve (44) and remove it from manifold (43).

Installation

 Before installing new drain valve, be sure old gasket (44a) and seat (44b) are not still inside manifold.

1. Thread drain valve (44) into manifold (43) opening.
2. Hand tighten securely. Using a wrench, torque to 120 to 130 in-lbs.
3. Turn valve stem so hole for pin (47) is positioned at 12 o'clock (pin can be temporarily inserted to turn valve stem).
4. Push base (45) over drain valve (44) and then drain handle (46) over base (45).
5. Replace pin (47) in drain handle (46). If necessary, use a hammer to tap it in place completely.

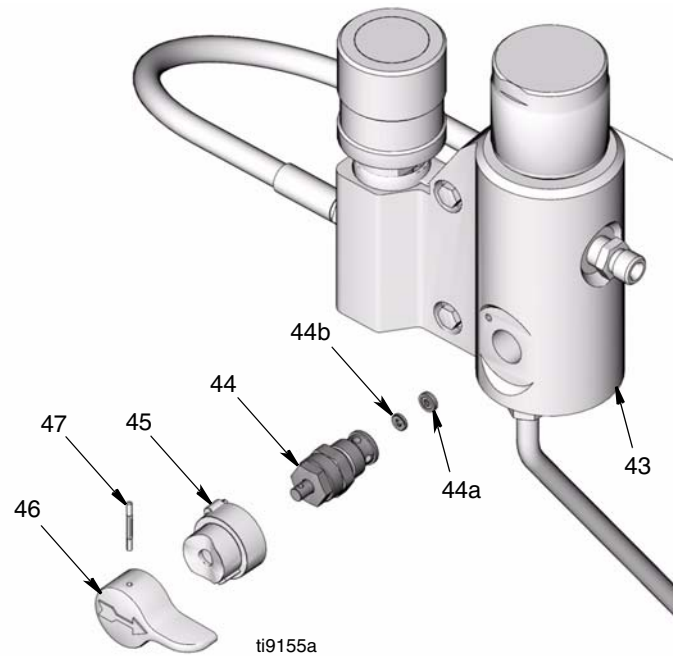

Drain Line Removal/Replacement

Removal

To remove the drain line (49) from the manifold:

1. Cut drain line (49) from barbed fitting (51).
2. Unscrew barbed fitting (51) from manifold.

 If you are only replacing the manifold and will be reusing the existing barbed fitting (51) and drain line (49), you will need to use a sharp knife to cut the remaining drain line material off the end of the barbed fitting (51).

Installation

1. Screw barbed fitting (51) into manifold.
2. Push drain line (49) onto barbed fitting (51).

 To make the drain line more pliable and easier to install over barbed fitting, heat end of drain line (49) with a hair dryer or by placing end in hot water a few seconds.

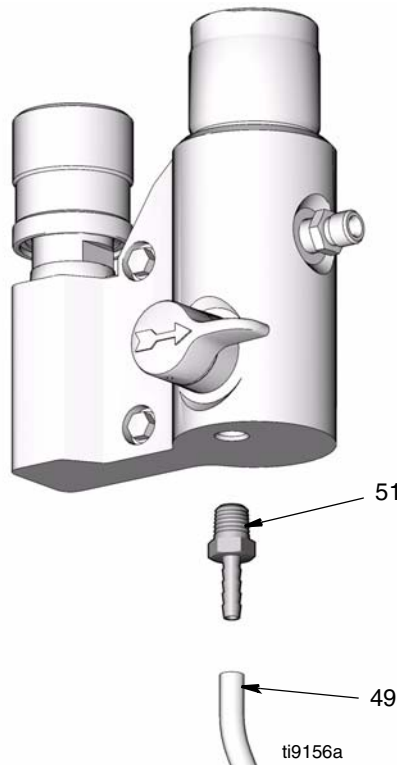

Power Cord Replacement

See **Wiring Diagram**, page 27.

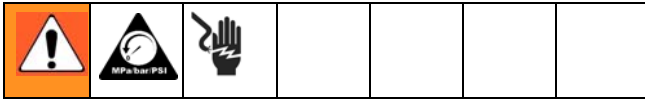

Removal

1. Follow **Control Board Replacement** removal instructions, steps 1-8, page 25.
2. Disconnect power cord connectors (C) from control board (18).
3. Disconnect green ground wire (G) from sprayer by loosening grounding screw (20).

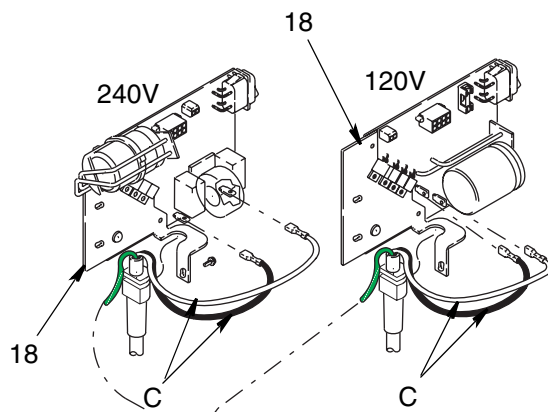

Installation

1. Follow **Control Board Replacement** installation instructions, steps 1-4, page 19.
2. Reconnect, green ground wire (G) to green grounding screw (20) on frame. Be sure terminal on ground faces UP or wires could get caught in shroud.
3. Reconnect power cord connectors (C) to control board (18).
4. Reattach motor connector (B) and pressure control switch connect (A).
5. Install shroud (12) and two screws (4) (see illustration, page 17).

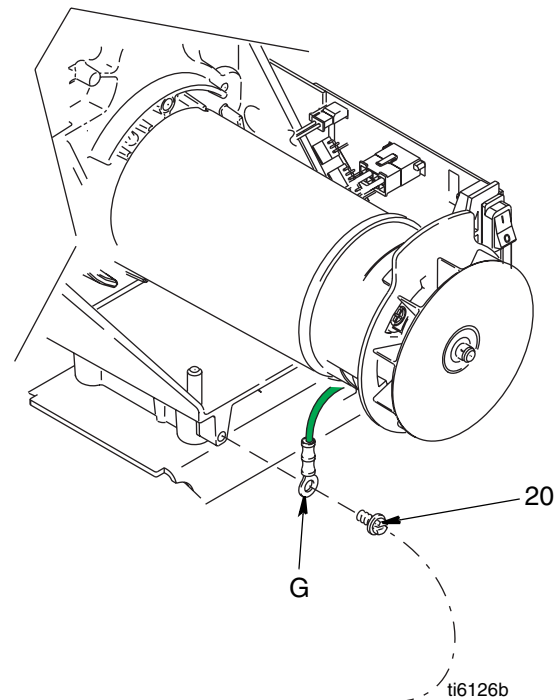

Motor Replacement

See **Wiring Diagram**, page 27.

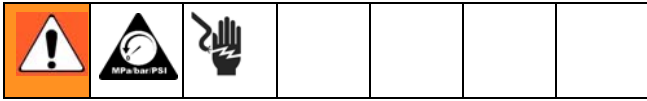

CAUTION

Do not drop gear cluster (3) and (2) when removing drive housing (5). Gear cluster may stay engaged in motor frontend bell or drive housing.

Removal

1. **Relieve pressure**, page 7. Disconnect power cord from outlet.
2. **Hi-Boy Model Only** - Disconnect high-pressure hose from pump outlet (see page 13).
3. Remove pump (33). **Displacement Pump Replacement**, page 13.
4. Remove drive housing, **Drive Housing Replacement**, page 15.
5. Remove Pressure (Fluid) Manifold, **Drain Valve Replacement**, page 23.
6. Disconnect all leads from board (18) and remove control board. **Control Board Replacement**, page 19.

7. Remove ground wire (G) from motor endbell.
8. Remove four screws (4) and motor (57) from frame (1).

Installation

1. Install new motor (57) on frame (1) with four screws (4).
2. Install fluid manifold (43) with two screws (4). **Drain Valve Replacement**, page 23.
3. Install control board (18) with three screws (11). Connect all leads to board. See **Control Board Replacement**, page 19 and **Wiring Diagram**, page 27.
4. Connect ground wire (G) to motor with green ground screw (20).
5. Install Drive Housing. **Drive Housing Replacement**, page 15.
6. Install pump (33). **Displacement Pump Replacement**, page 13.
7. Install shroud (12) with two screws (4) (see illustration, page 17).
8. **Hi-Boy Model Only** - Reconnect high-pressure hose at pump outlet (see page 14).

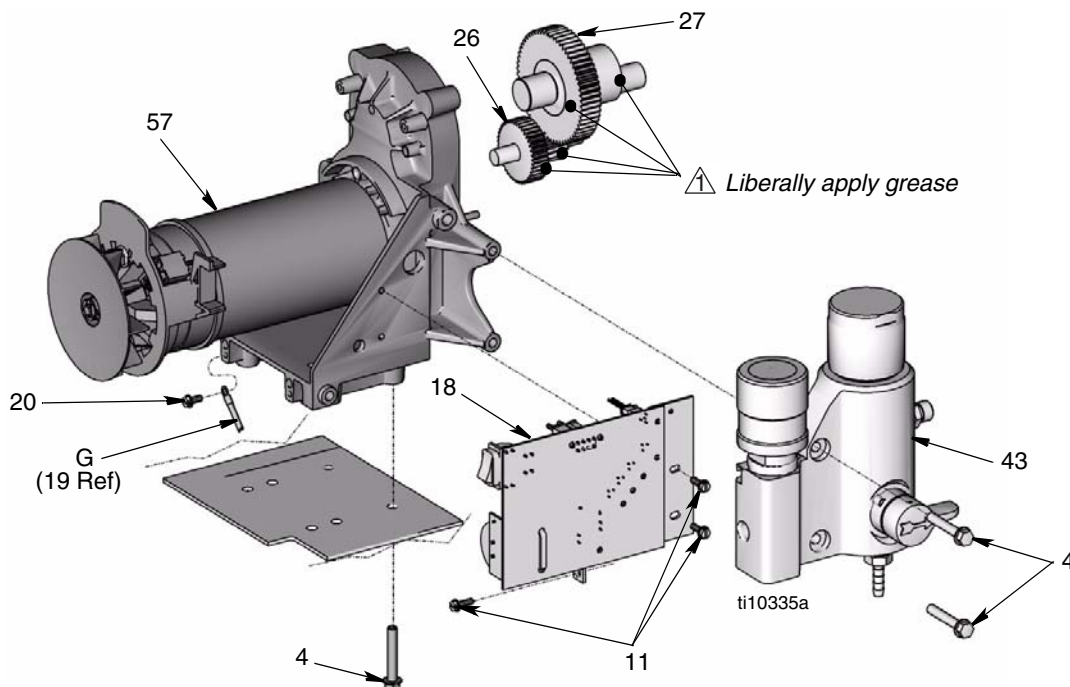

Wiring Diagram

120V Model

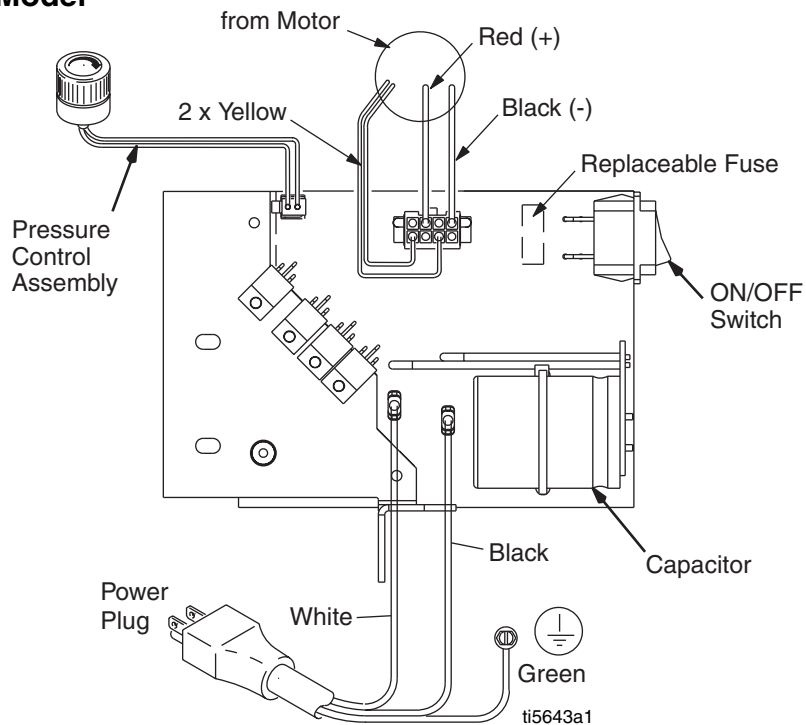

240V Model

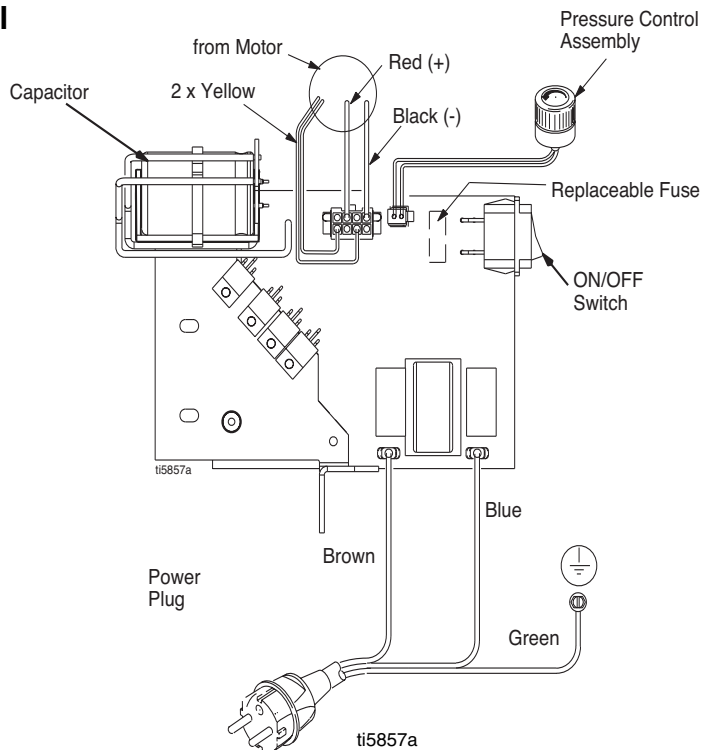

Parts (Stand)

Models 247482, 247483, 247484

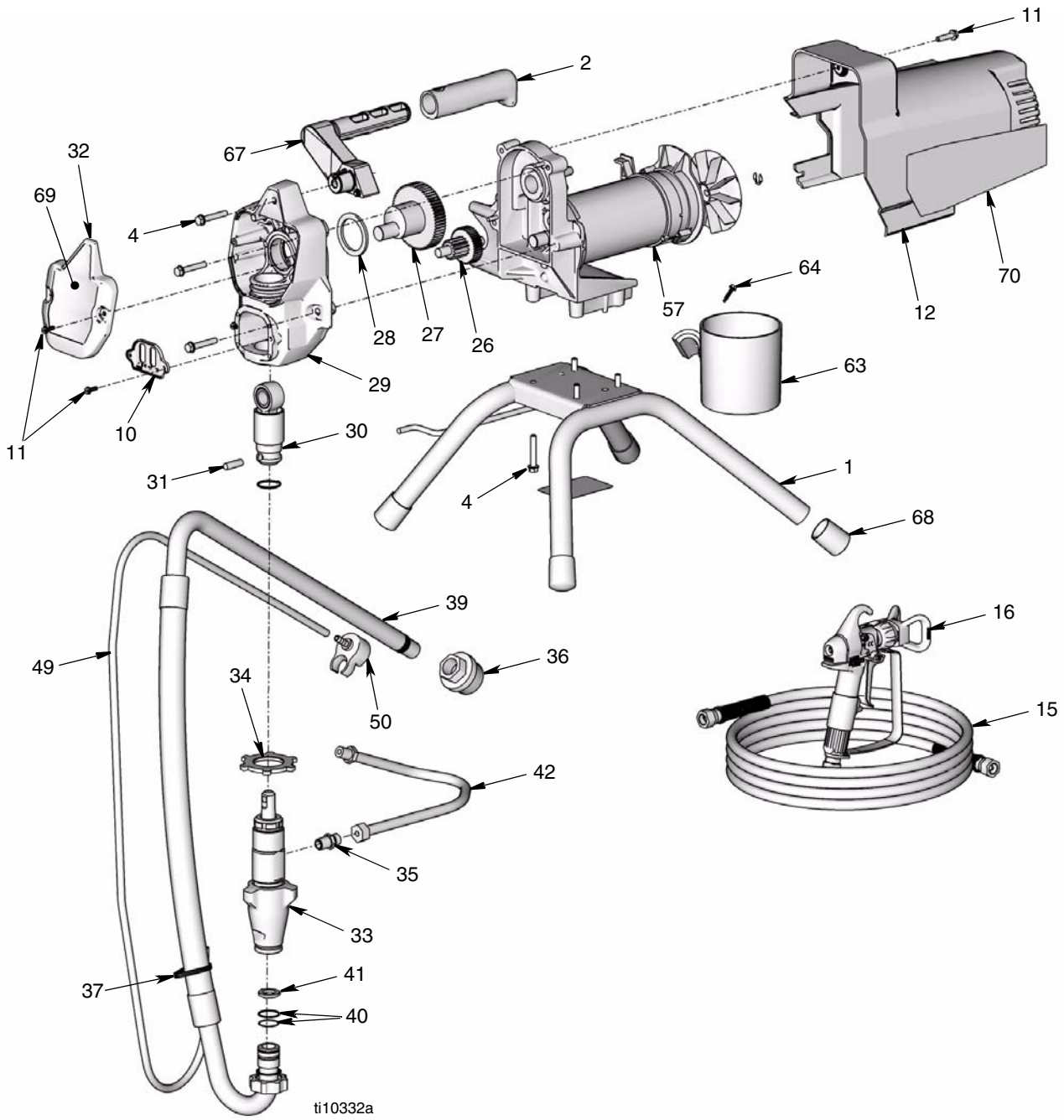

Parts (Stand)

Models 247482, 247483, 247484

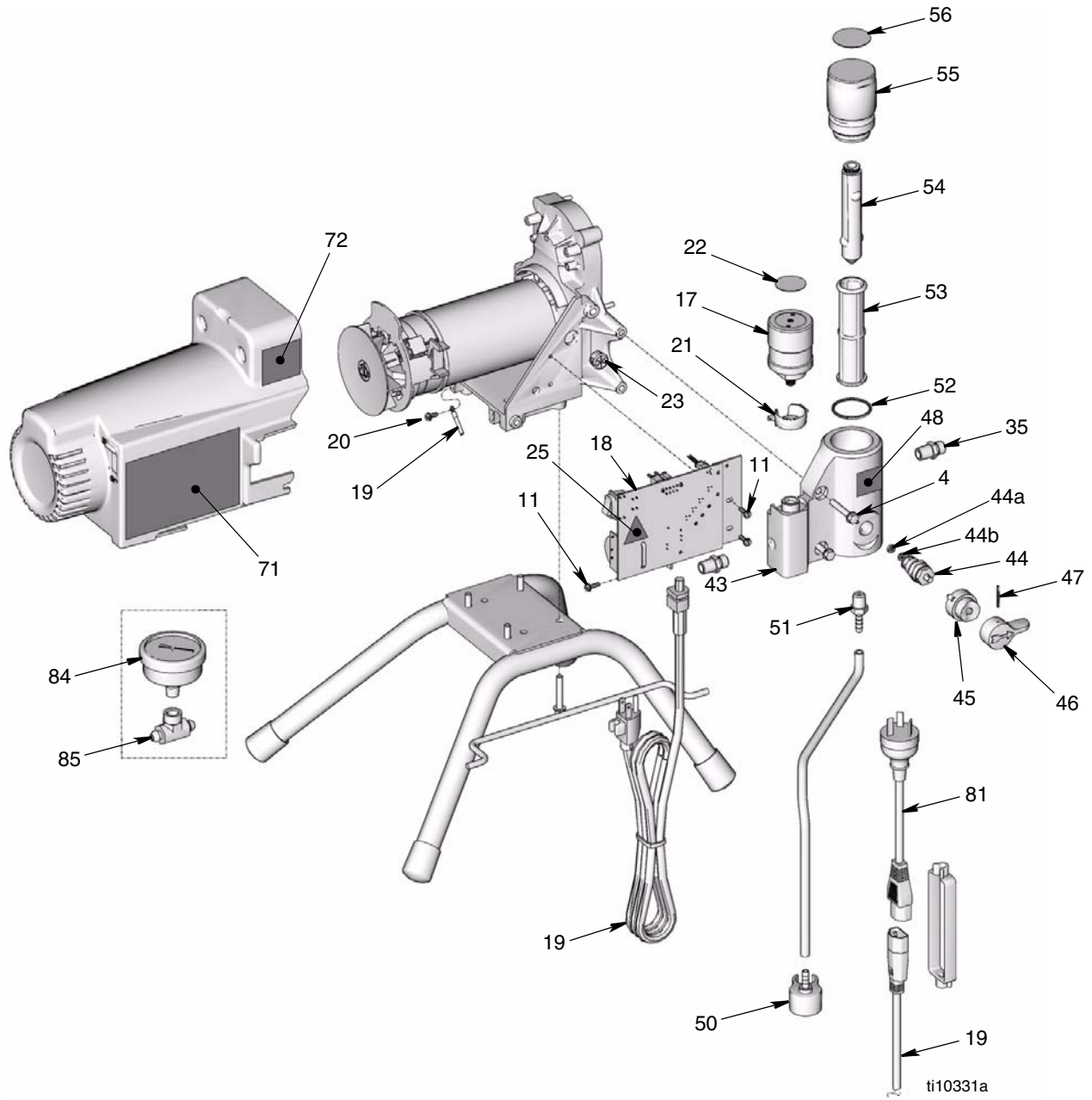

Parts List (Stand)

Models 247482, 247483, 247484

Ref	Part	Description	Qty	Ref	Part	Description	Qty
1	15E823	FRAME, stand mount	1	44a	111699	GASKET, seat	1
2	116139	GRIP, handle	1	44b	15E022	SEAT, valve	1
3	119723	TAPE, foam	1	45	224807	BASE, valve	1
4	117493	SCREW, mach, hex washer hd	11	46	187625	HANDLE, valve, drain	1
10	15B589	COVER, pump rod	1	47	111600	PIN, grooved	1
11	117501	SCREW, machine, hex washer head	9	48	195811	LABEL, instruction	1
12		KIT, shield, motor, includes 11, 71, 72, 70		49	249051	KIT, tube, drain, includes 51, 50, 37	1
	255432	Model 247482, 247484	1	50	244035	DEFLECTOR, barbed	1
	255433	Model 247483	1	51	M70809	FITTING	1
15	HSE1450	HOSE, cpld, 1/4 x 50 ft	1	52	104361	O-RING	1
16	289316	GUN #500 2 Finger	1	53 †	245527	FILTER, fluid, 60 mesh	1
17		CONTROL, pressure, includes 21, 23, 03		54	15E288	INSERT, filter	1
	249005	Models 247482, 247183 120V	1	55	15E289	CAP, filter	1
	248929	Model 247484 240V	1	56	195707	LABEL, identification	1
18 ‡		CONTROL BOARD		57 ♦		MOTOR, electric, includes 57a, 57b	1
	255483	Models 247482, 247483 (120V)	1		255485	Models 247482, 247483	1
	255484	Model 247484 (240V)	1		255486	Model 247484	1
19		CORD		57a	249043	FAN, motor, includes 57b	1
	15B119	Models 247482, 247483 (120V)	1	57b	119653	RING, retaining	1
	15B471	Model 247484 (240V)	1	63	15G838	CUP, suction/drain	1
20	115498	SCREW, mch, slot, hex, wash hd	1	64	115723	SCREW, drill, hex washer head	1
21	15E794	CAP, wire, control, pressure	1	67	276864	HANDLE, includes 4, 2	1
22	15F399	LABEL, control	1	68	112759	CAP, tubing	4
23	115756	BUSHING	1	69		LABEL, front	
25 ♦	189930	LABEL, caution	1		15M774	Model 247482, 247484	1
26	249194	GEAR, reducer	1		15M766	Model 247483	1
27	249195	GEAR, crankshaft, includes 28	1		70	LABEL, side	
28	180131	BEARING, thrust	1		15M775	Model 247482, 247484	1
29	255488	HOUSING, drive, includes 4, 11, 10	1		15M763	Model 247483	1
30	287053	ROD, connecting, includes 30a, 31	1	71 ♦	15K359	LABEL, warning	1
30a	196750	SPRING, retaining	1	72 ♦	195833	LABEL, warning	1
31	196762	PIN, straight	1	78	245651	FLUID, starter kit (not shown)	1
32	276883	COVER, front, includes 11, 69	1	81	242005	CORD SET ADAPTER (Australia)	1
33	255475	PUMP, displacement, includes 35 (Manual 312362)	1	84	115523	GAUGE, pressure, fluid; Model 254998	1
		NUT, jam, pump	1	85	119783	FITTING, swivel; Model 254998	1
34	195150	FITTING, (1/4 npsm x 1/4 npt)	2	89 ♦	179960	TAG, warning (not shown)	1
35	162453	STRAINER, 7/8-14 unf	1		‡119277	FUSE, replacement	
36	246385	STRAP, tie	1		‡249042	KIT, brush, motor, replacement	
37	114958	HOSE, suction set, includes 41, 40, 36	1				
39	246386	O-RING	2				
40	117559	WASHER, garden hose	1				
41	115099	HOSE, cpld	1				
42	15M670	MANIFOLD, filter	1				
43	15J745	VALVE, drain, includes 44a, 44b	1				
44	235014		1				

♦ Replacement Danger and Warning labels, tags, and cards are available at no cost.

† Other filters available: 245528, 100 mesh; 245526, 200 mesh.

Parts (Hi-Boy)

Models 247485, 247486, 247487, 247494, 247495, 247531, 247532

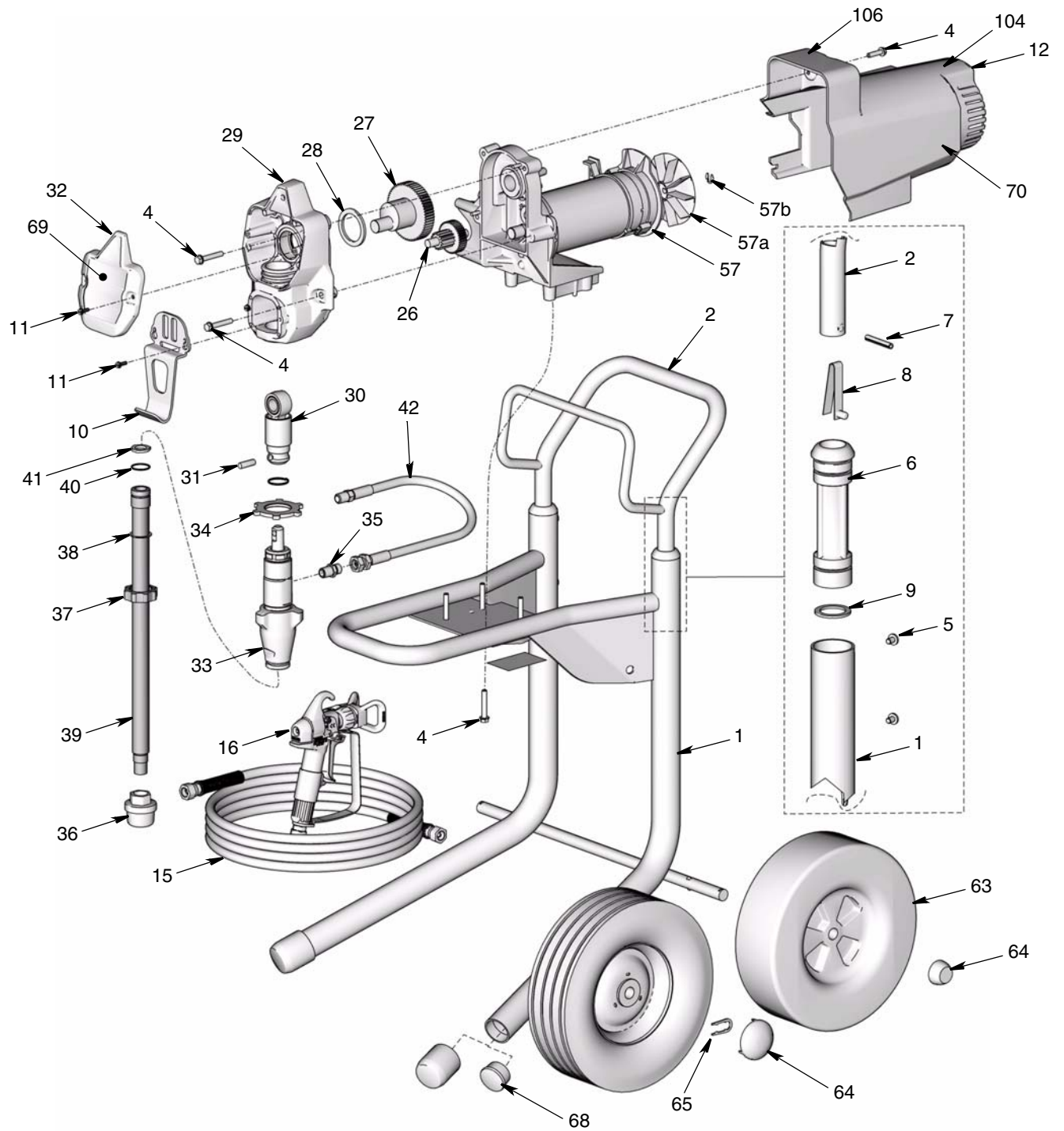

Parts List (Hi-Boy)

Models 247485, 247486, 247487, 247494, 247495, 247531, 247532

Ref	Part	Description	Qty	Ref	Part	Description	Qty
1	288216	FRAME, cart, hi	1	57a	249043	FAN, motor	1
2	245245	HANDLE, cart	1	57b	119653	RING, retaining	1
4	117493	SCREW, mach, hex washer hd	10	63		WHEEL, semi pneumatic	
5	109032	SCREW, mach, pnh	4		119451	Models 247485, 247486, 247487, 247531, 247532	2
6	192027	SLEEVE, cart	2		119730	Models 247494, 247495	2
7	101354	PIN, spring straight	2	64		CAP, hub	
8	111590	BUTTON, snap	2		119452	Models 247485, 247486, 247487, 247531, 247532	2
9	15J645	WASHER	2		104811	Models 247494, 247495	2
10	15J812	HANGER, pail	1	65		CLIP, retaining	
11	117501	SCREW, mach, slot hex wash hd	7		15B999	Models 247494, 247495	2
12		KIT, shield, motor (includes 4, 70, 71, 72)		68		CAP, leg	
	255434	Models 247485, 247487	1		15C871	Models 247485, 247486, 247487, 247531, 247532	2
	255435	Model 247486	1		277091	Models 247494, 247495	2
	255492	Models 247494, 247495	1	69		LABEL, front, brand	
	255490	Model 247531	1		15M775	Models 247485, 247487	1
	255491	Model 247532	1		15M763	Models 247486	1
15	HSE1450	HOSE, cpld, 1/4 in. x 50 ft	1		15R669	Models 247494, 247495	1
16	289316	GUN #500 2 Finger	1		15M777	Model 247531	1
26	249194	GEAR, assembly, combination	1		15M768	Model 247532	1
27	249195	GEAR, crankshaft; includes 28	1	70		LABEL, side, brand	
28	180131	BEARING, thrust	1		15M774	Models 247485, 247487	1
29	255487	HOUSING, drive; includes 4, 10, 11	1		15M766	Model 247486	1
30	287053	ROD, connecting; includes 30a, 31	1		15M772	Model 247494, 247495	1
30a	196750	SPRING, retaining	1		15M776	Model 247531	1
31	196762	PIN, straight	1		15M765	Model 247532	1
32	276883	COVER, front	1	78	245651	FLUID, TSL, 8 oz (not shown)	1
33	255475	PUMP, displacement; includes 35 Manual 312362	1	90	115523	GAUGE, pressure, fluid Models 247487, 247494, 247495	1
34	195150	NUT, jam, pump	1	91	119783	FITTING, swivel Models 247487, 247494, 247495	1
35	162453	FITTING, (1/4 npsm x 1/4 npt)	2	104	15R613	LABEL, shroud top Models: 247494, 247495	1
36	235004	STRAINER, 3/4-16 unf	1	106	15R616	LABEL, crown Models: 247494, 247495	1
37	15E813	NUT, jam	1				
38	15B652	WASHER, suction	1				
39	15J801	TUBE, suction, intake	1				
40	103413	O-RING	1				
41	115099	WASHER, garden hose	1				
42	15M671	HOSE, cpld	1				
57❖		MOTOR, electric (includes 57a, 57b)					
	255485	Models 247485, 247486, 247494, 247531, 247532	1				
	255486	Models 247487, 247495	1				

Y Warning labels are available free of charge
❖ 249042 KIT, brush, motor

Parts (Hi-Boy)

Models 247485, 247486, 247487, 247494, 247495, 247531, 247532

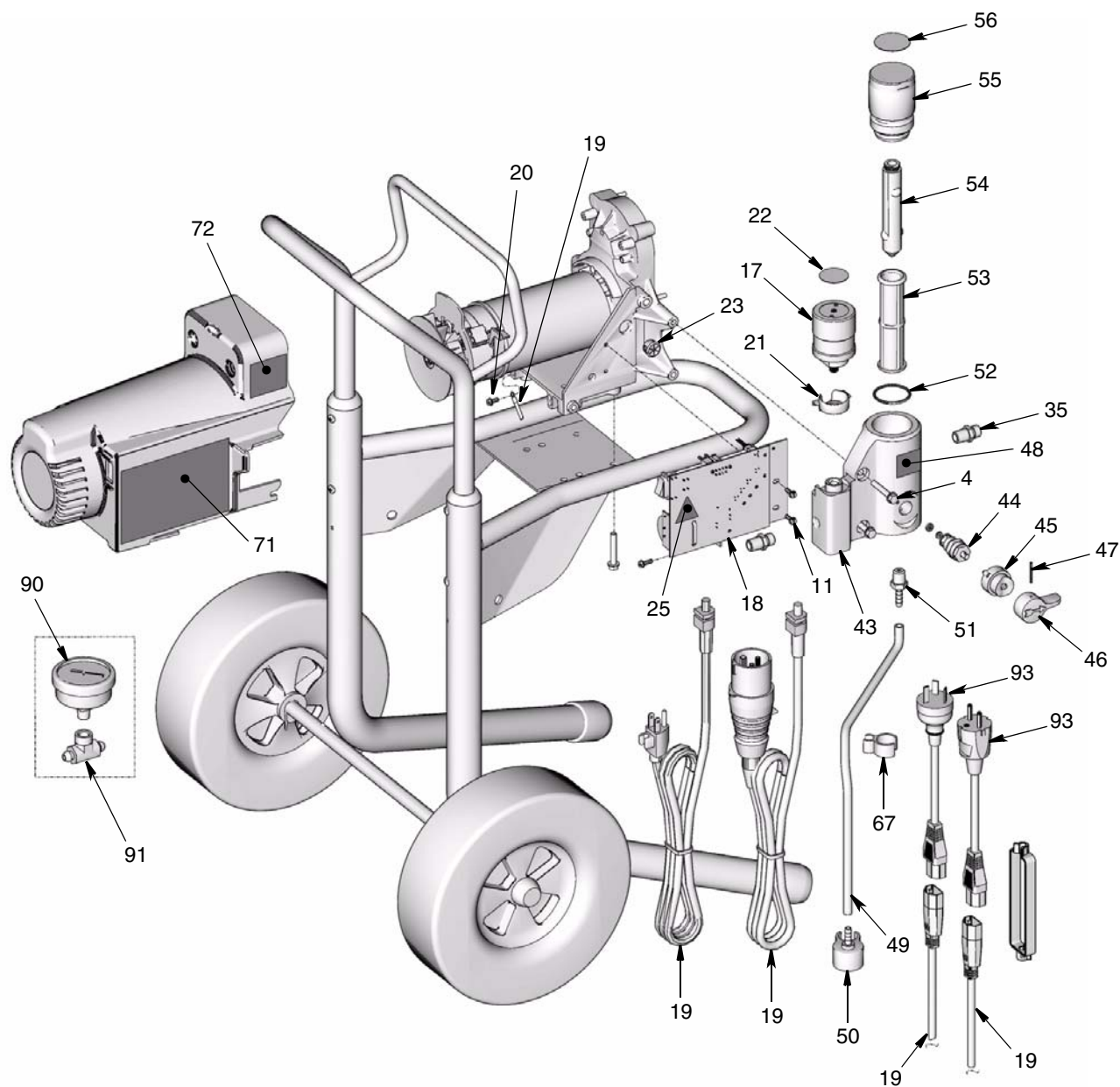

Parts List (Hi-Boy)

Models 247485, 247486, 247487, 247494, 247495

Ref	Part	Description	Qty	Ref	Part	Description	Qty
4	117493	SCREW, mach, hex washer hd	10	277089	Models 247494, 247495		1
11	117501	SCREW, mach, slot hex wash hd	7	47	111600	PIN, grooved	1
17		CONTROL, pressure (includes 21, 22, 23)		48	195811	LABEL, instruction	1
	249005	Models 247485, 247486, 247494, 247531, 247532 (110V)	1	49	15K092	TUBE, drain	1
	248929	Models 247487, 247495 (240V) CONTROL, board	1	50	DEFLECTOR, barbed		
18	255483‡	Model 247485, 247486, 247494, 247531, 247532 (110V)	1	244035	Models 247485, 247486, 247487, 247531, 247532		1
	255484‡	Models 247487, 247495 (240V) CORD, power	1	255465	Models 247494, 247495		1
19	15B119	Models 247485, 247486, 247531, 247532 (110V)	1	51	M70809	FITTING, barbed, hose	1
	15B471	Models 247487, 247495 (240V)		52	104361	O-RING	1
	15B469	Model 247494 (110V)	1	53†	245527	FILTER, fluid, 60 mesh	1
20	115498	SCREW, mach, slot hex wash hd	1	54	15E288	INSERT, manifold	1
21	15E794	CAP, wire, control, pressure	1	55	15E289	CAP, filter	1
22	15F399	LABEL, pressure control knob	1	56	195707	LABEL, identification	1
23	115756	BUSHING, universal	1	67	195400	CLIP, spring	1
25	189930	LABEL, caution	1	71Y	15K359	LABEL, 190-210 261825 261830 war	1
43	15J745	MANIFOLD, Filter, 190/210 ES	1	72Y	195833	LABEL, warning	1
44	235014	VALVE, drain; includes 44a, 44b	1	93	CORD SET ADAPTER		
44a	111699	GASKET, seat	1	242005	Model 247487		1
44b	15E022	SEAT, valve	1	242001	Model 247495		1
45	224807	BASE, valve	1				
46		HANDLE, valve, drain					
	187625	Models 247485, 247486, 247487, 247531, 247532	1				

YWarning labels are available free of charge

‡ 119277 Fuse replacement

† Other filters available: 245528, 100 mesh; 245526,
200 mesh.

Technical Data

Power requirements	100/120V AC, 50/60 hz, 11A, 1 phase 240V AC, 50/60 hz, 7.5A, 1 phase
Generator required	3000 w minimum
Maximum working pressure	3300 psi (22.7 MPa, 227 bar)
Cycles per gallon (liter)	680 (180)
Maximum delivery gpm (lpm)	0.37 (1.4): Models 247494, 247495 0.47 (1.8): Models 247485, 247486, 247487, 247494, 247495 0.54 (2.0): Models 247531, 247532
Maximum tip size	0.019: Models 247494, 247495 0.021: Models 247485, 247486, 247487, 247494, 247495 0.023: Models 247531, 247532
Fluid outlet npsm.	1/4 in.
Dimensions (Stand): 247482, 247483, 247484	
Length	15.75 in. (40.0 cm)
Width	14.0 in. (36.0 cm)
Height	17 in. (43.0 cm)
Weight	30 lbs (13.6 kg)
Weight (with gauge)	31 lbs (14.0 kg)
Dimensions (Hi-Boy): 247485, 247486, 247487, 247494, 247495, 247531, 247532	
Length	22.0 in. (55.9 cm)
Width	20.5 in. (52.1 cm)
Height	38.8 in. (98.6 cm)
Weight	59 lbs (26.8 kg)
Weight (with gauge)	60 lbs (27.2 kg)
Wetted parts	zinc and nickel-plated carbon steel, nylon, stainless steel, PTFE, Acetal, leather, UHMWPE, aluminum, tungsten carbide
Noise level*	
Sound power (ISO 3744)	100dBa*
Sound pressure (ISO 3744)	90 dBa*
<i>*Measured 3 feet (1 meter) from equipment.</i>	

ASM Standard Warranty

ASM warrants all equipment referenced in this document which is manufactured by ASM and bearing its name to be free from defects in material and workmanship on the date of sale by an authorized ASM distributor to the original purchaser for use. With the exception of any special, extended, or limited warranty published by ASM, ASM will, for a period of twelve months from the date of sale, repair or replace any part of the equipment determined by ASM to be defective. This warranty applies only when the equipment is installed, operated and maintained in accordance with ASM's written recommendations.

This warranty does not cover, and ASM shall not be liable for general wear and tear, or any malfunction, damage or wear caused by faulty installation, misapplication, abrasion, corrosion, inadequate or improper maintenance, negligence, accident, tampering, or substitution of non-ASM component parts. Nor shall ASM be liable for malfunction, damage or wear caused by the incompatibility of ASM equipment with structures, accessories, equipment or materials not supplied by ASM, or the improper design, manufacture, installation, operation or maintenance of structures, accessories, equipment or materials not supplied by ASM.

This warranty is conditioned upon the prepaid return of the equipment claimed to be defective to an authorized ASM distributor for verification of the claimed defect. If the claimed defect is verified, ASM will repair or replace free of charge any defective parts. The equipment will be returned to the original purchaser transportation prepaid. If inspection of the equipment does not disclose any defect in material or workmanship, repairs will be made at a reasonable charge, which charges may include the costs of parts, labor, and transportation.

THIS WARRANTY IS EXCLUSIVE, AND IS IN LIEU OF ANY OTHER WARRANTIES, EXPRESS OR IMPLIED, INCLUDING BUT NOT LIMITED TO WARRANTY OF MERCHANTABILITY OR WARRANTY OF FITNESS FOR A PARTICULAR PURPOSE.

ASM's sole obligation and buyer's sole remedy for any breach of warranty shall be as set forth above. The buyer agrees that no other remedy (including, but not limited to, incidental or consequential damages for lost profits, lost sales, injury to person or property, or any other incidental or consequential loss) shall be available.

ASM MAKES NO WARRANTY, AND DISCLAIMS ALL IMPLIED WARRANTIES OF MERCHANTABILITY AND FITNESS FOR A PARTICULAR PURPOSE, IN CONNECTION WITH ACCESSORIES, EQUIPMENT, MATERIALS OR COMPONENTS SOLD BUT NOT MANUFACTURED BY ASM. These items sold, but not manufactured by ASM (such as electric motors, switches, hose, etc.), are subject to the warranty, if any, of their manufacturer. ASM will provide purchaser with reasonable assistance in making any claim for breach of these warranties.

In no event will ASM be liable for indirect, incidental, special or consequential damages resulting from ASM supplying equipment hereunder, or the furnishing, performance, or use of any products or other goods sold hereto, whether due to a breach of contract, breach of warranty, the negligence of ASM, or otherwise.

FOR ASM BRAZILIAN/CANADIAN/COLUMBIAN CUSTOMERS

The Parties acknowledge that they have required that the present document, as well as all documents, notices and legal proceedings entered into, given or instituted pursuant hereto or relating directly or indirectly hereto, be drawn up in English.

TO PLACE AN ORDER OR FOR SERVICE, contact your ASM distributor,
or call 1-800-854-4025 to identify the nearest distributor.

*All written and visual data contained in this document reflects the latest product information available at the time of publication.
ASM reserves the right to make changes at any time without notice.*

MM 312361

ASM Company, 3500 N. 1st Avenue, Sioux Falls, SD 57104
www.asmcompany.com
02/2008